

## Simple moped wiring diagrams

This is a diagram of the very minimum wiring that is required on thyristor ignition models to provide ignition power only for testing your engine or for off road use only, without any lights or horn. Instead of the handle bar "kill" button you could fit an on-off toggle switch into the red lead from the generator to the G terminal of the thyristor unit.

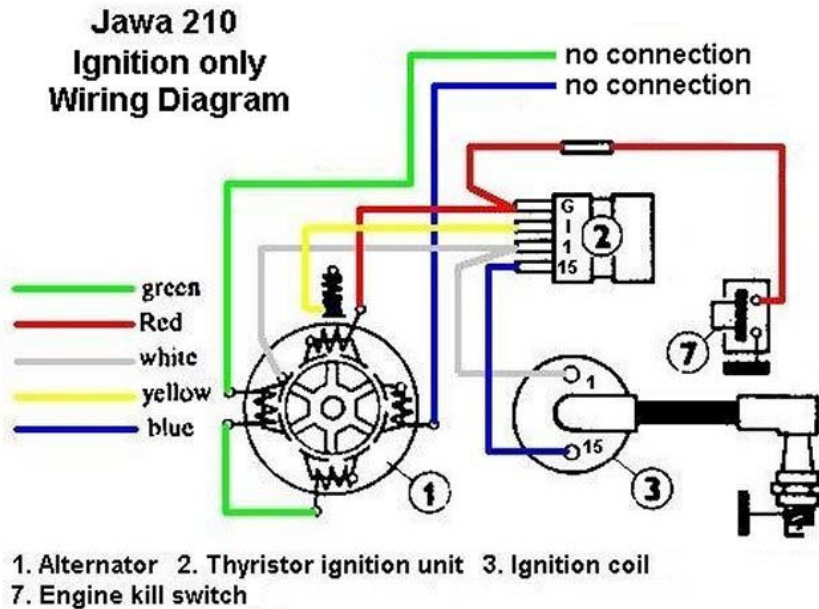

[www.jawamoped.com](http://www.jawamoped.com)

The Type 20, 21, 23, scooter and Mustang models are even simpler to wire up, just the black wire from the points to the coil and a push button to earth so that you can stop the engine once it is running.

### **Jawa 20,21,23 Ignition only Wiring Diagram**

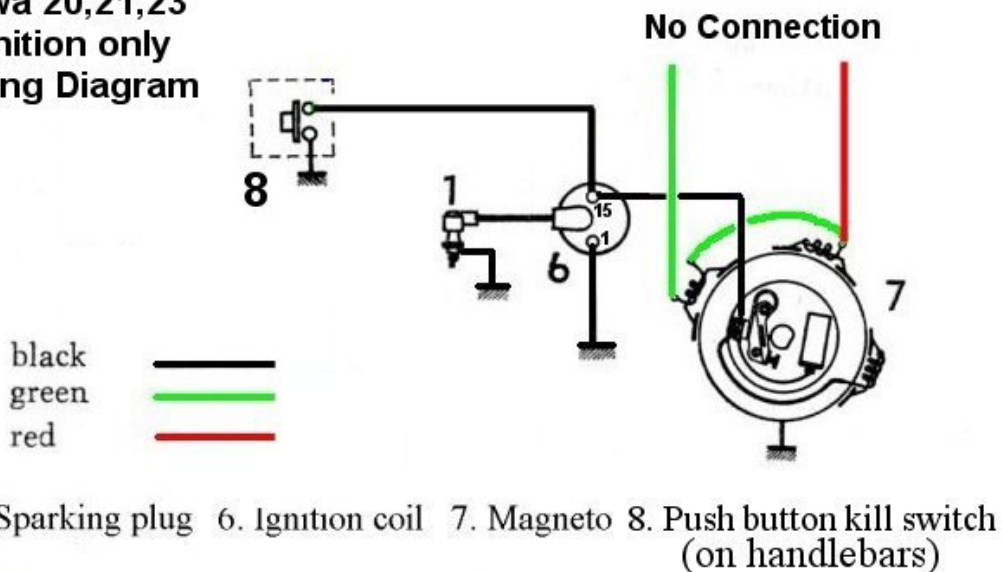

[jawamoped.com](http://www.jawamoped.com)