

SERVICING AND MAINTENANCE INSTRUCTIONS

babetta

Ultra - Lightweight Motorcycle - type 28

Cylinder capacity	49 cm ³
Engine output	1,5 HP at 4500 r. p. m.
Maker	Považské strojárne, Považská Bystrica
Exporter	Motokov - Prague - CSSR

The moped is the motor vehicle having a very simple service and maintenance due to its automatic clutch and one-stage gear box. Despite of this the careful study of this booklet is recommended to you before its use in order to get acquainted with its servicing and maintenance. Thus many failures will be avoided and the moped will serve you to your full satisfaction.

Much pleasure and many satisfied kilometers with the moped.

**Považské strojárne
Považská Bystrica**

All rights of design alteration resulting from the moped development, as far the illustrations and the description given in this booklet are given, are reserved.

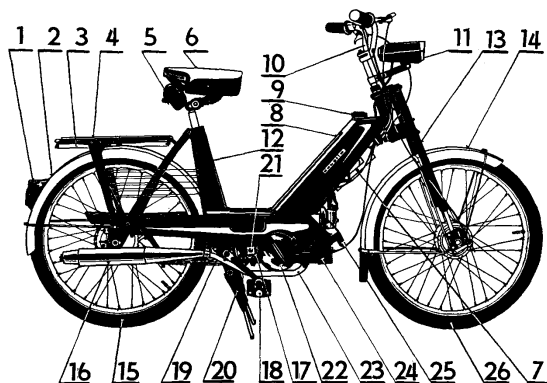

Fig. 1. Babetta Moped – Main Parts

1. Tail lamp
2. Rear mud guard.
3. Pump.
4. Luggage carrier.
5. Bag with tools.
6. Seat.
7. Suction filter.
8. Fuel tank.
9. Fuel tank plug.
10. Handlebars.
11. Headlamp.
12. Frame.
13. Front fork.
14. Front mudguard.
15. Rear wheel.
16. Exhaust silencer.
17. Chain of engine.
18. Pedals.
19. Chain of pedals.
20. Stand
21. Engine disengaging.
22. Alternator (under cowl).
23. Exhaust knee piece.
24. Engine.
25. Spark plug with cable shoe.
26. Front wheel.



Table of Contents

I.	Technical Data	6
II.	Control elements and their servicing	9
III.	Riding instructions	11
IV.	Maintenance and adjustment of vehicle	18
V.	Tools	38
VI.	Defects and their remedies	39
VII.	Spare parts	44

I. TECHNICAL DATA

- Type of engine - two-stroke, air-cooled, single cylinder
 Cylinder capacity - 49 cm³
 Bore of cyl. x piston stroke - 39 x 41 mm (1.55 x 1.61")
 Compression ratio - 1 : 6.5
 Output - 1.5 HP, 4500 r. p. m.
 Clutch - dry, automatic, centrifugal
 Gear box - one stage
 Overall gear ratio to rear wheel - 1 : 15.75
 Ratio of pedals to rear wheel - 1 : 0.568
 Starting - by means of pedals
 Front springing - telescopic fork without shock absorber
 Stroke of front springing - 60 mm (2.36")
 Brakes - drum shoe brake operated by the levers on the handle bars
 Brake size - 85 X 20 mm (3.35 X 0.79")
 Tyres - 23 X 2"
 Inflation of tyres: Front - 1.5 - 1.75 atm. eff. (24 psi)
 Rear - 2 - 2.25 atm. eff. (30 psi)
 Weight of vehicle - 42 kg (92.6 lbs)
 Carrying capacity - 90 kg (220 lbs)
 Velocity - Permanent - 35 km/hr. (32 m. p. h.)
 Maximum - 40 km/hr. (25 m. p. h.)
 Fuel tank capacity - 3 litres (res. 0.5) 2.64 Imp. pt. (0.88)
 Maximum climbing ability - 10 %
 Noise level - 73 dB
 Ignition - contactless, by means of semiconductors
 Sparking plug - PAL 14-5 R
 Headlight - 21 W, 6V
 Rear light - 5 W, 6 V
 Bell - smooth
 Basic fuel consumption- 0.37 galls/62 miles (1.7/100 km)
 by 16 miles/hour (27 km/hour)

II. VEHICLE CONTROL ELEMENTS

The moped is easy to operate and for its servicing:

Are required the following elements only:

- Throttle twist grip (1, fig. 2) the rotation of which disengages and engages automatically the clutch by releasing and throttling the gas and further this is used to regulate the velocity of vehicle.
- Front brake (2, fig. 2) and rear brake (3, fig. 2) levers by means of which the moped is braked and stopped
- Decompressor lever (4, fig. 2) by means of which the engine is stopped or the start is facilitated.
- Buzzer push-button (5, fig. 2)
- Dip switch (fig. 3). The buzzer and the front and rear lights may be in operation during the engine function only.
- Fuel tap (fig. 4)
- Air closing push button (fig. 5)
- Pedals (fig. 6)
- Disengaging the engine (fig. 7)

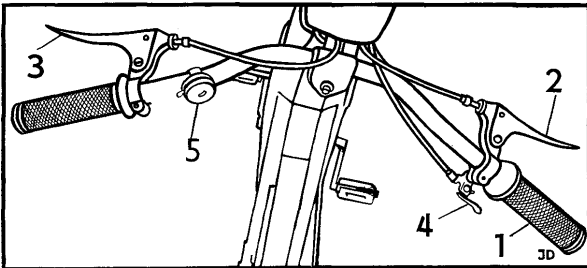

Fig. 2. Steering of vehicle

1 Gas grip, 2. Front brake lever, 3. Rear brake lever, 4. De-compressor lever, 5. Bell

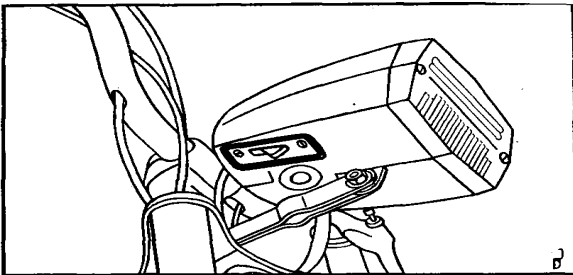

Fig. 3. Switch of lights

(in the lower part of headlamp)

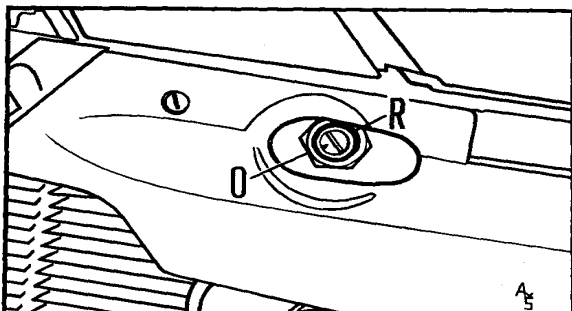

Fig. 4. Fuel tap O-opened fuel supply, R-reserve

Running-in new motorcycle

Thoroughly run-in new moped influences its output, consumption and service life. Take into consideration the following instructions when running-in:

- Drive mixture - M2T oil with 80 octanes petrol be mixed in ratio 1:25,
- This ratio keep during the running-in (500 km abt.), with maximum opening half rotation of throttle twist grip (speed abt. 20 km/hr.),
- When longer drives we recommend to lubricate the engine by opening he throttle. When riding downhill we do not recommend to throttle the gas but to use the rear brake.
- When stopping let the engine run at idle speed and ovoid to open the throttle uselessly.

III. RIDING INSTRUCTIONS

Check before the drive

- the correct function of brakes
- the inflation of tyres
- fuel level in the tank
- the function of buzzer and lights (during the engine run)

Filling the fuel tank

As the fuel is used the petrol mixed with oil. Maintain the specified ratio of oil and petrol, at the fuel pump take this ratio, is observed; Use as a minimum 80-octanes petrol. The tank is to be filled with the funnel provided with strainer.

Starting the cold engine

Open the fuel tap (fig. 4) press the push button of air closure (fig. 5) up to contact (after depressing the pin jumps out, the air, however remains shut) There are two kinds of starting the engine. Starting the cold engine during the summer period.

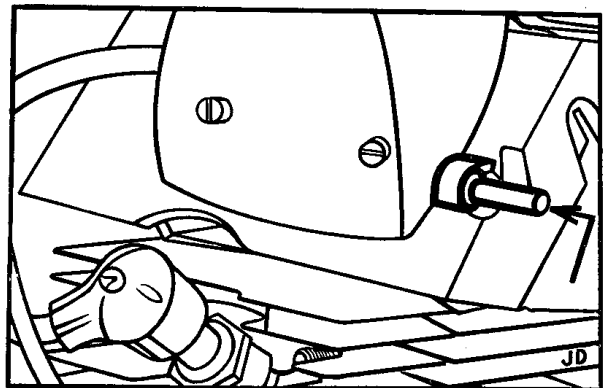

Fig. 5. Air closing push button

Starting the cold engine during the summer period

a) start on stand: this is made in such a way the moped is put on the stand, the air closure push button arranged on the carburettor is depressed, the decompressor lever is depressed the gas grip is rotated to $\frac{1}{2}$ of gas grip rotation range, the pedal is put abt. 30° from the perpendicular position in the direction forward, the pedal is kicked suddenly and before the final kicking the pedal into lower dead position (when the engine has the sufficient speed) the decompressor lever is released. The engine start to work Repeat this if required. After starting it is necessary to let the engine to warm up, after warming up rotate the gas grip up to contact due to what the air closure valve of carburetor is opened. By rotating the gas grip backward the engine works on idle run and it is ready for the drive. The vehicle is put from the stand on the wheels and by releasing the gas the start is effected.

b) Start by kicking: The vehicle is put on the wheels, the air closure push button on the carburettor is depressed, the decompressor lever is depressed, the gas grip as in the point a) is rotated. The vehicle is put in motion due to kicking and when the sufficient velocity is obtained the decompressor lever is released, the motor starts and by releasing the gas its velocity is increased. If required during the drive, especially when drive uphill the engine may be aided by kicking the pedal.

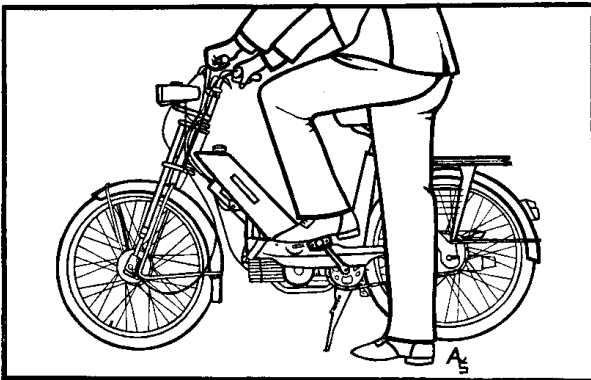

Fig. 6. Starting the engine

Start of warm engine (after shorter drive interruption).

The methods mentioned under a) and b) may be used. It is not necessary to depress the air closure on the carburettor.

Start of engine during the cold weather (in the winter)

When the temperature of atmosphere sinks below 0°C the start is to be effected as follows: Start is made as under point a) with that difference before the start the pedal is to be kicked several times to loosen the individual mechanisms which stiffen due to the cold. One can help out by depressing the decompressor lever.

The start itself is effected as under point a) (with that difference the gas grip is rotated to $\frac{3}{4}$ of range - the air valve should not open). The number of kickstarts increases proportionally to the sinking temperature of atmosphere. The method of start under b) on the ice covered roads is not recommended for the safety reasons.

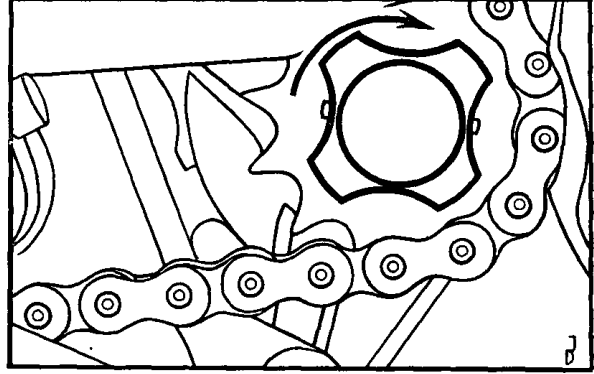

Fig. 7. Disengaging the engine

Braking and stopping

In the case the braking is required release the gas grip with brake levers (2,3 fig.2) and brake down. One proceeds in the same way when stopping the vehicle. The clutch disengages due to the velocity decrease and the engine works on idle run. If the drive is continued due to the releasing of gas the clutch is engaged again and the vehicle is put in motion. After finishing the drive the engine is to be stopped by depressing the decompressor lever (4, fig.2) and shut the supply of fuel by rotating the fuel tap lever (fig.4) to the position C. The position of lever B is the reserve and it is sufficient for the drive of abt. 30 km.

On the moped as on the cycle

If you want to use the moped as the cycle (e.g. when consumption of fuel) depress the disengaging device of engine - the star-like nut in the direction in the engine and rotate to the right (fig.7). the nut remains fitted into this position and the engine remains disconnected. The engine is engaged again when you depress again the star-like nut in the direction into the engine and rotate it to the left.

IV. MAINTENANCE AND ADJUSTMENT

Maintenance of vehicle

When cleaning the varnished and chrome plated vehicle parts use always the water and saponates. After washing the varnished and chrome plated parts wipe them with buck leather. The plastic and rubber parts of air filter are to be washed by the water only. The varnished and rubber parts and plastics do not wash by kerosene, petrol or another diluent since these parts could be deteriorated,

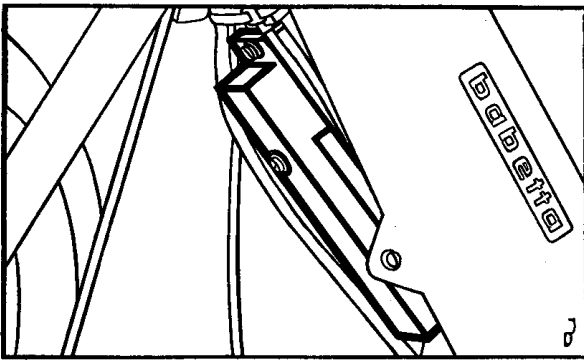

Fig. 8 Air filter

The air filter element (fig. 8) is to be washed from time to time in petrol. Clean from time to time the hole B of exhaust silencer (fig 9) from the carbon. When bigger decrease of output check whether the exhaust silencer is not choked by the carbon. The exhaust end piece is able to be pulled out after screwing out the nut A.

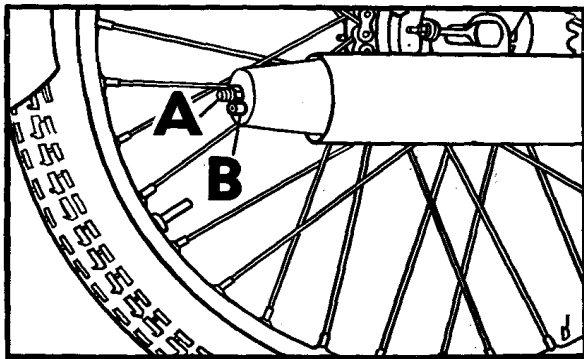

Fig. 9 Exhaust silencer

The oil in the gear box is to be changed after the ride only, when the oil and the engine are warm. Unscrew the discharge screw from the engine

bottom part (2, fig.11). After discharging the oil it is suitable to wash the gear box by the rinse oil. Fill the new gear oil through the filling hole 1 up to control orifice 3. From time to time check the oil level in the gear box and refill if required.

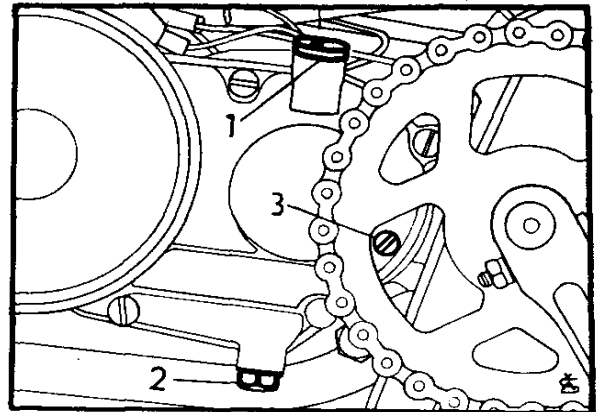

Fig. 11 Filling and discharging oil screw

- 1. Filling hole screw, 2. Discharge oil screw
- 3. Control hole

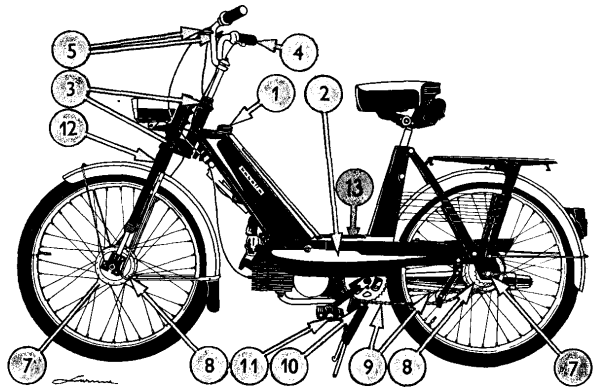

Fig. 10 Lubrication of vehicle

Lubrication Table (fig. no. 10)

Fig.	Lubrication point	Lubricant kind	Notes
1	Engine	oil for two stroke engines SAE 30 M2 T	permanent lubrication, Oil and petrol ratio 1:30 charge 0.02 galls, (0.13 lt)
2	Gear box	gear oil SAE 30-80 (PP 80)	
3	Steering	bearing grease (AV 2)	wash and grease when dismantling apply on the sliding parts after washing
4	Gas twist grip	grease (A00)	
5	Brake and decompressor levers	oil SAE 30 (M 6A)	fill in bowdens refill in bearings grease with small quantity after cleaning clean and grease as required
6	Bowdens	thin oil	
7	Wheel bearings	bearing grease (AV 2)	
8	Brake cam pin, cams, brake shoe pins	grease (A 00)	
9	Chains	graphite oil, grease (A 00)	
10	Stand pin	oil SAE 30 (M 6A)	
11	Pedal bearings	oil SAE 30 (M 6A)	
12	Front telescopic forks	oil SAE 30 (M 6A)	
13	Idling run wheel	oil SAE 30 (M 6A)	

VEHICLE MAINTENANCE SURVEY

After driving**first 800 km (500 miles)**

- change the oil in the gear box
- adjust and clean the carburetter
- tighten the cylinder head nuts
- tighten the seat nuts
- adjust and grease the chain
- adjust the brakes

first 1500-2000 km (930-1300 miles)

- decarbonize the exhaust silencer and exhaust knee piece

first 2000 km (1300 miles)

- change the oil in the gear box
- clean the carburetter
- clean the suction filter element
- adjust and grease the chain
- adjust the brakes
- check the tightening of screws
- check tightening of nuts and spokes of wheels
- grease the bowdens

every 6000 km (4000 miles)

- clean and check the spark plug
- change the oil in the gear box
- clean the carburetter
- clean the suction filter element
- adjust and grease the chain
- adjust the brakes
- check the tightening of screws
- check tightening of nuts and spokes of wheels
- grease the vehicle

Idling run wheel chains greasing and cleaning the brakes be effected more oftenly if rainy weather. The other maintenance including the greasing is to be effected as required.

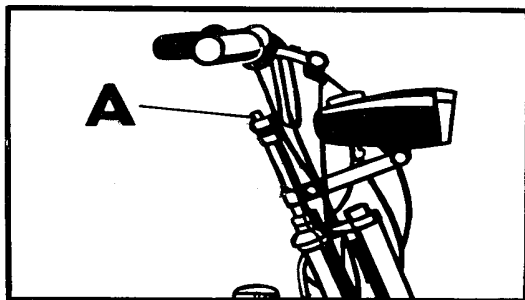

Fig. 13 Adjustment of handlebars height

Adjustment of height of seat and handlebars

The height of seat and handlebars may be adjusted by the driver as required. The inclination of seat is adjusted after loosening of nut A (fig.12). The tightening of nut A is to be checked from time to time to avoid the tear of holder teeth. The height of seat is adjusted after loosening of nut B. This is able to be adjusted in the limits of 120 mm. The height of handlebars may be adjusted after loosening of screw A ~~and both nuts B~~ (fig.13) within the limits of 100 mm. After adjustment of seat and handlebars the nuts and the screws are to be tightened thoroughly.

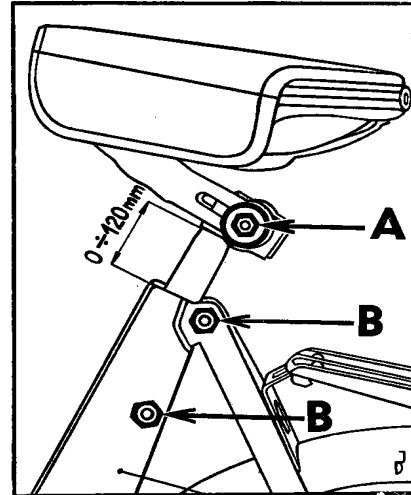

Fig. 12 Adjustment of seat

Adjustment of brakes

For the current adjustment of front and rear brakes are used the screws arranged on the handlebars (fig.14). When adjustment loosen the knurled nut (1) and by screwing in or out the screw (2) is taken up the clearance of brake lever so that after the compression the lever is distant from the handle 20 to 30 mm. After adjustment of brake the nut (1) is to be tightened.

If the brakes are not able to be tightened by the screws arranged on the handlebars these may be adjusted on the brake cams, (fig.15 and fig.16) by tightening the brake cable. Then the final regulation of brake adjustment is to be effected by the screws arranged on the handlebars.

Check after adjustment of brakes whether these are not tightened too much. Put the moped onto the stand and ascertain by rotating the wheels whether these rotate freely without the jerks.

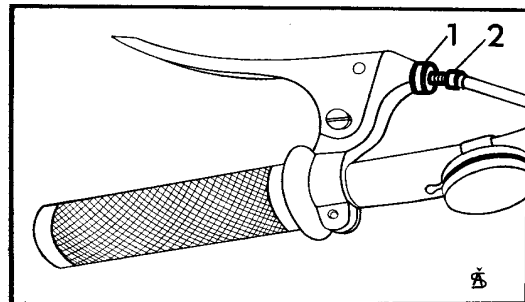

Fig. 14 Adjustment of brakes

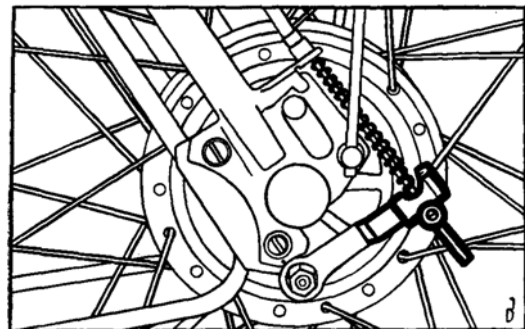

Fig.15 Adjustment of front brake

Adjustment of chains

The chain of the engine is adjusted after loosening the nut of rear axle (3 fig.16). By tightening the nuts of chain tightener (2) on both sides of frame tighten the chain so it has the clearance of abt. 10mm after the compression. After the adjustment of chain check the trace of the wheels by means of straight lath and tighten thoroughly the nuts of the axle. The chain of the pedals is adjusted by means of tension pulley arranged on L. H. side of the moped (fig. 17).

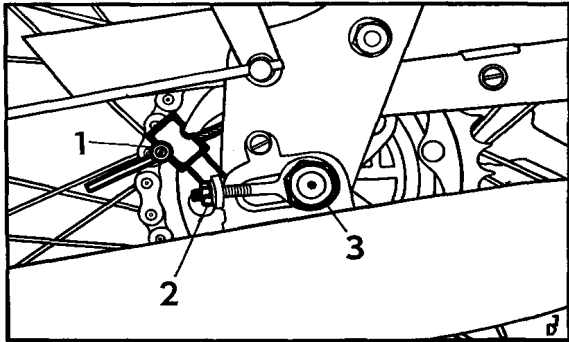

Fig. 16 Adjustment of rear brake and engine chain

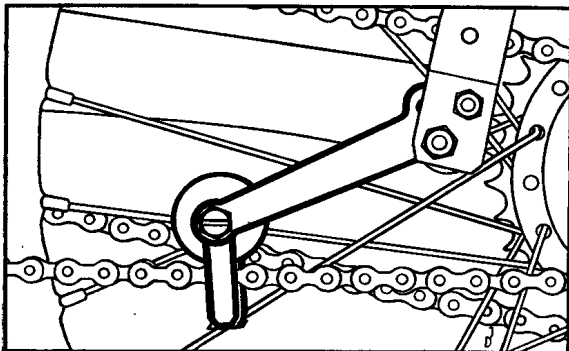

Fig. 17 Adjustment of chain of pedals

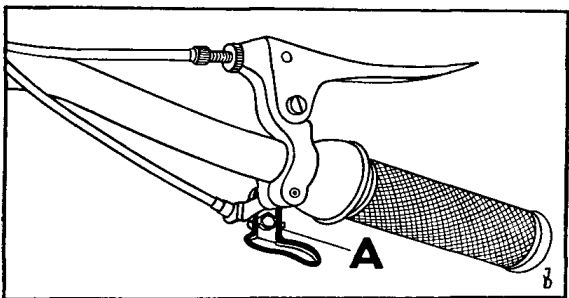

Fig. 18 Adjustment of decompressor

Decompressor adjustment

The decompressor is adjusted after loosening the screw A (fig.18) on the decompressor lever. The cable is loosened or pulled so the clearance of bowden from the stop B is 1 - 1,5mm (fig.19). Tighten the screw after adjustment of clearance of cable.

The clearance of the cable must have the prescribed value since at the tightened cable the burning through of decompressor valve would take place. The decompressor does not function with the free cable.

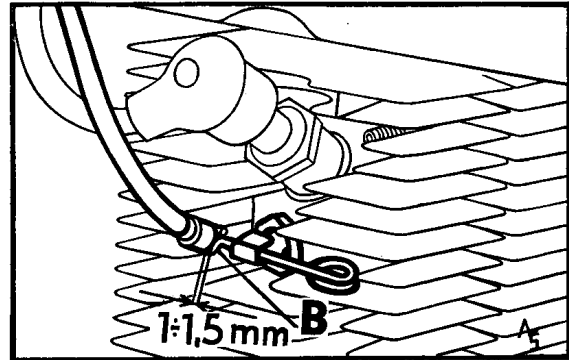

Fig. 19 Checking the decompressor adjustment

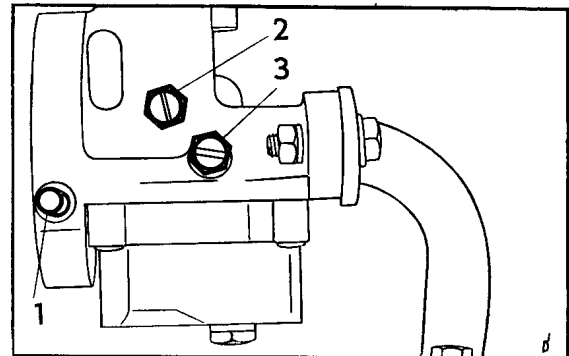

Fig. 20 Carburettor 1. Saturator pin. 2. Mover stop screw. 3. Regulating screw for richness of idle run mixture.

Carburettor (Fig. 20)

When failure of carburettor we would like to recommend you to apply to the service repair shop which effects the repair, adjustment and cleaning of the carburettor. The nozzles are to be cleaned by the petrol and compressed air only. Jikov 2909 DC carburettor has the following equipment and adjustment used for Babetta moped:

- main nozzle 63
- idle run nozzle 35
- mover needle adjusted on 2nd. Notch from upward
- regulation screw of mixture richness for idle run loosened backwards through 1½ rotation.

The stop screw of the mover is used for adjustment of idle run r.p.m. The speed increased by screwing in and decreased by screwing out.

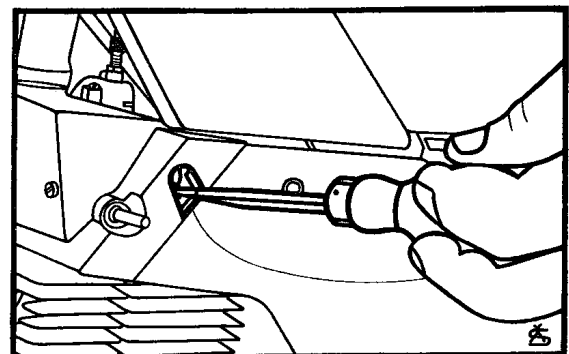

Fig. 21 Adjustment of carburettor

Ignition

The moped is equipped with contactless semiconductor ignition which does not require any servicing and maintenance except the temporary cleaning of plug and the failure may take place only due to the not qualified intervention by the user. No advanced ignition is required to be adjusted since no mechanical wear takes place. The advanced ignition is to be adjusted after loosening the screws of stator only or after dismantling the alternator. We recommend you therefore not to intervene into the adjustment of ignition. In the case of failure apply to the specialised repair shop.

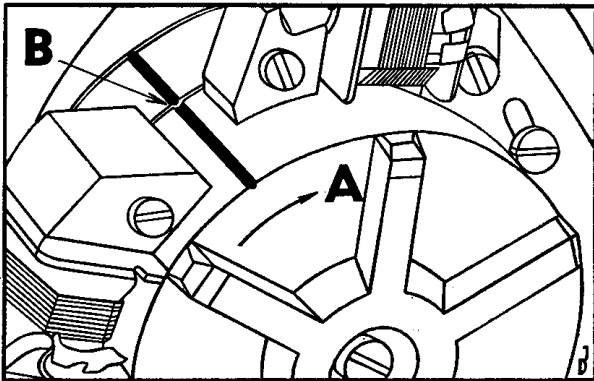

Fig. 22 Adjustment of advanced ignition I

When adjustment of advanced ignition the rotor is to be rotated in the direction of arrow A (fig.22) till coincide B-lines of rotor and stator. Insert the dial indicator or depth gauge into the plug hole and measure the depth of insertion. Then rotate further the rotor in the direction of arrow A up to the upper piston position. The distance on the dial indicator from the coincidence of the lines up to the upper dead center should be 1 - 1.5 mm. If this value is higher, loosen the screws E (fig.23) and rotate the stator in the direction of arrow C, when lower value rotate the stator in the direction of arrow D.

This operation is to be effected so till the value of advanced ignition of 1 - 1.5 mm is reached. After adjustment tighten thoroughly all screws and check the correctness of adjustment again.

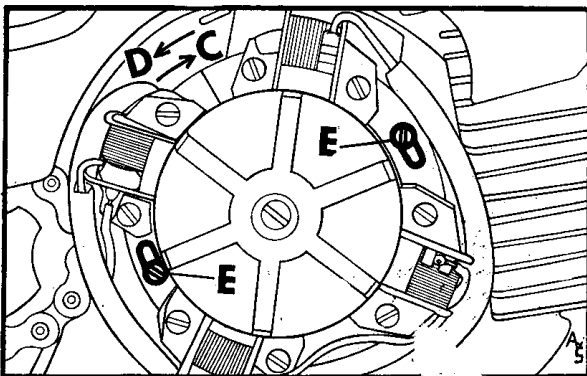

Fig. 23 Adjustment of advanced ignition II

V. TOOLS

The tools are accommodated in the bag arranged under the seat. The content is:

combined spanner
screwdriver 3 mm
spanner 10 mm
spanner 19/21 mm
handle Ø 5 mm
handle Ø 6 mm
lock
pump (is accommodated under the luggage carrier)

VII. SPARE PARTS

The serial number of vehicle and the manufacture year are shown on the name plate accommodated on the front part of frame. The engine number is stamped on the engine box. The serial number is intended for the registration of moped. When ordering the spare parts from the sales agent or from the sales shop give always this serial number and manufacture year of moped. The moped holders are recommended to keep the following spare parts:

Refer. No.	Name of part
28-5240	Gas bowden complete
28-5247	Rear brake cable
28-5256	Front brake cable
28-5265	Decompressor cable
60304	Headlamp bulb PS25-1, 6V, 2W Ba15s
60600	Tail lamp bulb C11, 6V, 5W, SV8.5
62088	Sparking plug 14-5 R
55017	inner tube 23X2"
28-7227	Petrol hose

Published: After-Sale Service Department,
Považské strojárne,
n. p., Považská Bystrica, Czechoslovakia

VI. DEFECTS AND THEIR REMEDIES

Discovered failure			Remedy		
Lumpy running	Engine missfires	Engine overheats. Plug electrodes are overheated, the faulty plug (not corresponding thermal value). Too much carbon in the cylinder head and in the exhaust duct. Big advanced ignition. Exhaust silencer choked.	Wait till the engine is cooled do not run at high speed. Change the plug. Remove the head and dismantle the exhaust, remove the carbon. Regulate the advanced ignition. Dismantle the silencer & clean it.		
		Water or oil in carburetor. Insufficient fuel supply into carburetor. Leakage in the crank case Poor mixture (white exhaust gas)	Clean the carburetor. Open fully the fuel tap (especially the reserve), refill the fuel, check the supply piping, clean the aerating hole in the plug. Check the tightness of crank case and change the sealing if required. Adjust the carburetor, clean the nozzle.		
	Engine missfires	Correct spark	Incorrectly mixed petrol with oil.	Mix correctly the fuel	
		Irregular spark	Not suitable plug Oiled plug	Change the plug The plug is to be screwed out and cleaned	
The engine will not fire or stops	Defects in the fuel supply	No fuel in the tank. The fuel tap in the supply piping is closed or insufficiently opened. Choked fuel filter above the tap. The choked piping or strainer in the carburetor. The choked hole in the plug hole. The choked nozzle in carburetor. Leaky float, Needle valve does not shut.	Open the fuel tap to reserve. Open the fuel tap. The fuel tap be removed & filter cleaned. Dismantle the piping & carburetor and clean the nozzle and blow it through. Clean the de-aerating hole. Screw out the nozzle and clean it. Solder or change it. Change the damaged valve.		
		Oiled plug. Damaged plug insulation. Short circuit between the plug electrodes. Big distance of plug electrodes. Bonding of plug to the frame due to water or mud.	Change the plug or clean it. Change the plug. The electrodes are to be separated to the distance of abt. 0.7 mm. The electrodes are to be brought to the distance of 0.7 mm. Change and dry the terminal the plug and the cable		
The engine does not fire or stops	The carburetor and fuel supply faultless	The plug does not give the spark	Spark at the cable end	Burnt cable insulation. Damaged cable shoe. Faulty Tranzimo unit or transistor only.	The cable is to be wound with insulating tape and changed as soon as possible, change the terminal. Change the cable shoe. Change the Tranzimo unit or transistor only.
			No spark at the cable end	Broken piston ring. Seized piston ring. Sealing under the plug is leaky. Seized piston.	Remove ring from the piston & replace it by new one. Remove the ring, clean it and put it in again. Replace the sealing by a new one. Dismantle and repair.
	The plug is correct.	Engine has no compression.	The plug gives the spark.	Overheated engine. Insufficient lubrication. Broken gas cable. Bad sealing between the carburetor and cylinder.	The engine is to be allowed to cool down and to be held on lower speed. Care be taken the oil with petrol is in correct ratio and thoroughly mixed through. Change the cable or repair it. Change the sealing, tighten the flange.
				Too much settled carbon in the cylinder, head and exhaust silencer. Partially choked fuel supply. Wrong adjustment of firing. Wrongly regulated carburetor. Seized carburetor mover. Choked exhaust silencer. Worn interior of lid and piston.	Dismantle the head, cylinder, and exhaust and remove the carbon. Diamantle the piping and clean it. Adjust the advanced ignition. Adjust idle run, needle position & clean the air filter. Loosen the mover and adjust it. Clean the exhaust silencer. New re-bore of cylinder, new piston and rings.
Engine output is insufficient	Permanently	The engine sucks false air (the box halves or carburetor flange do not seal).	Damaged sealing ring. The cylinder head does not seal. The brake shoes rub against the drums. Choked air filter.	The box halves are to be separated , the contact surfaces be cleaned, the sealing substance be applied and mount firmly, change the sealing under the carburetor flange. Change the sealing ring. Grind it. Adjust the brakes. Clean it.	
			Partially choked fuel supply or the strainer in the top of carburetor. The gas cable seizes. Faulty plug. Overheated engine. Fallen out needle lock in carburetor	The fuel supply or the strainer are to be cleaned. Oil the cable, respectively change it. Change the plug. Let the engine cool down and keep it on low speed. New lock.	
	Periodically				
Clutch slips.			Dirty clutch jaws.	Clean the jaws, check sealing of clutch (sealing rings).	