

# BMW



## Operation and Maintenance Manual

# DANDY MJ50

## Operation and Maintenance Manual

*Dear friends,*

*you have become the owners of Dandy 50 motorcycle that was manufactured in MotorJikov, a joint stock company, in České Budějovice, Czech Republic.*

*This late type of two-seat motorcycle has renewed interrupted tradition in manufacturing of Stadion mopeds that were the top products of Czech motorcycle industry in their time. Besides the motorcycle production MOTOR JIKOV is renowned company also in the field of Manufacture of car accessories and small two-stroke and double-stroke engines.*

*The motorcycle you have chosen has been designed using up-to-date computer art and experience of leading designers of motorcycles, taking special care of drive safety and driving characteristics. The materials used for the motorcycle are manufactured according to the latest knowledge of metallurgy and petrochemical industry, and therefore they guarantee high reliability and long service life of all its parts.*

*The operation and maintenance manual includes all basic data of your motorcycle; using the manual you will be familiarized with service, maintenance and technical data of the motorcycle in details. There is also a section devoted to troubleshooting of smaller failures in the manual.*

*Before the first drive read these instructions carefully. Observing all advices and instructions, MOTOR JIKOV's motorcycle will serve you well.*

*A great deal of plesure in driving your „Dandy“!*

**MOTOR JIKOV**

## 2. Table of Contents

<b>1) Introduction</b>	<b>1</b>	8.13. Rear Wheel Brake Check and Adjustment	23
<b>2) Table of Contents</b>	<b>2</b>	8.14. Excessive Effect of Brakes	23
<b>3) Technical Data</b>	<b>3-6</b>	8.15. Rear Stop Light Switch	24
3.1. Engine	3	8.16. Front Stop Light Switch	24
3.2. Undercarriage	3-4	8.17. Chain Tightening	24
3.3. Electric Equipment	4	8.18. Chain Cleaning	25
3.4. Working Liquids	4-5	8.19. Front Wheel Mounting and Dismantling	25
3.5. Other Data	5-6	8.20. Rear Wheel Mounting and Dismantling	25
<b>4) Technical Description</b>	<b>7</b>	8.21. Telescopic Fork	25
4.1. Identification Marking	7	8.22. Steering Bearing Clearance Check	26
<b>5) Familiarization with Motorcycle before Drive</b>	<b>8-12</b>	8.23. Wheel Bearing Check	26
5.1. Control Elements	8	8.24. Side Stand Check	26
5.2. Brake Control	9	8.25. Exhaust Equipment Decarbonization	26
5.3. Clutch Control	9	8.26. Headlight Adjustment	26
5.4. Gear Shifting	9	8.27. Lamp Replacement	27
5.5. Fuel Cock Control	10	8.28. Fuse Replacement	27
5.6. Choke Lever Control	10	8.29. Battery Check	28
5.7. Side Stand	10	8.30. Electric Installation Diagram	29
5.8. Tool Box	10	8.31. Table of Failures	28
5.9. Machine Locking	11	<b>9) Care of the Motorcycle</b>	<b>30-31</b>
5.10. Working Liquid Refilling	11-12	9.1. Motorcycle Cleaning	30
<b>6) Motorcycle Check before Drive</b>	<b>13</b>	9.2. Motorcycle Storage	30
6.1. Brake Check	13	9.3. Winter Operation and Protection against Corrosion	30-31
6.2. Clutch Check	13	9.4. Fuel Saving	31
6.3. Gas Grip Check	13	9.5. Ecologic information	31
6.4. Chain Check	13		
6.5. Tyre Check	13		
6.6. Wheel Check	13		
6.7. Electric Installation Check	13		
<b>7) Driving the Motorcycle</b>	<b>14-15</b>		
7.1. Motorcycle Starting	14		
7.2. Motorcycle Setting in Motion	14-15		
7.3. Motorcycle Stopping	15		
7.4. Engine Running-In	15		
<b>8) Adjustment and Maintenance</b>	<b>15-29</b>		
8.1. Lubrication and Maintenance Schedule	16-17		
8.2. Torques	17		
8.3. Table of Lubricants	18		
8.4. Gear Oil Level Check	18		
8.5. Gear Oil Replacement	18		
8.6. Fuel Cock Cleaning	19		
8.7. Air Filter Cleaning	19		
8.8. Carburetter Check	20		
8.9. Sparking Plug Check	20		
8.10. Ignition	20		
8.11. Clutch Check and Adjustment	21		
8.12. Front Wheel Brake Check and Adjustment	22		

### 3. Technical Data

#### 3.1. Engine

Type	SACHS 50/5 AKF SACHS 50/5 AKF I * SACHS 50/5 AKF. ** SACHS 50/5 AKF I. **	SACHS 50 S
Number of cylinders		1
Cylinder bore/Piston stroke		38 mm/44 mm
Cylinder capacity		49.9 ccm
Compression ratio	11.5:1	10:1
Engine max. power	2.6 kW 5,700 rpm	46 kW 8,000 rpm
Max. torque	5.1 N.m / 3,500 rpm	5.8 N.m / 7,500 rpm
Fuel consumption	2.1 l/100 km	2.5 l/100 km
Engine lubrication		oil and petrol mixture
Lubrication ratio		1:30 (1:40) See Section 5. 10
Oil tank volume*	*separated lubrication of the engine 1.3	
<b>Carburetter</b>	BLNG 18/15/101 dif. Ø 15 mm	BNG 21/20/127 dif. Ø 19 mm
Main jet	78	80
Idle-run jet	30	45
<b>Ignition</b>		
With light coil		
Type	contactless ignition ISKRA	contactless ignition VAPE
Light power		12 V/80 W
<b>Sparking plug</b>		
Type	BOSCH W 5 BC BRISK N 17 NGK B6 HS CHAMPION L-81	BOSCH W 3 A BRISK L N 14 NGK B8 HS CHAMPION L-78
Electrode spacing		0.5 - 0.6 mm
<b>Gearshift mechanism</b>		
a) Primary drive by gears with helical teeth		
Ratio		3.21
b) Secondary drive by chain		
Ratio	2.71 (3.09)**	2.53
c) Clutch		multi-plate.in oil bath
Number of metallic plates		4
Number of friction plates		5
Control		mechanical
d) Gearbox		
Number ofgears		5
I		4.6gear ratio
II		2.73
III		1.95
IV		1.59
V,		1.375
Neutral between		I and II

#### 3.2 Undercarriage

Type cradle-shaped double frame welded from steel sections (ring, square and rectangular)

#### Suspension

a) Front fork telescopic, with hydraulic stop  
Stroke 170 mm  
b) Rear fork swinging, with central springing unit  
Stroke 150 mm



**Rear absorber**

- a) Oil AMG 10
- b) Volume 100 ccm

**Front disk brake**

- a) Brake fluid Synthol HD-205  
Classification DOT 3
- b) Volume 40 ccm

**3.5. Other Data**

**Dimensions**

- Length 1,950 mm
- Width 700 mm
- Height 1,070 mm
- Seat height 800 mm
- Wheel base 1,320 mm
- Ground clearance 240 mm

**Weights**

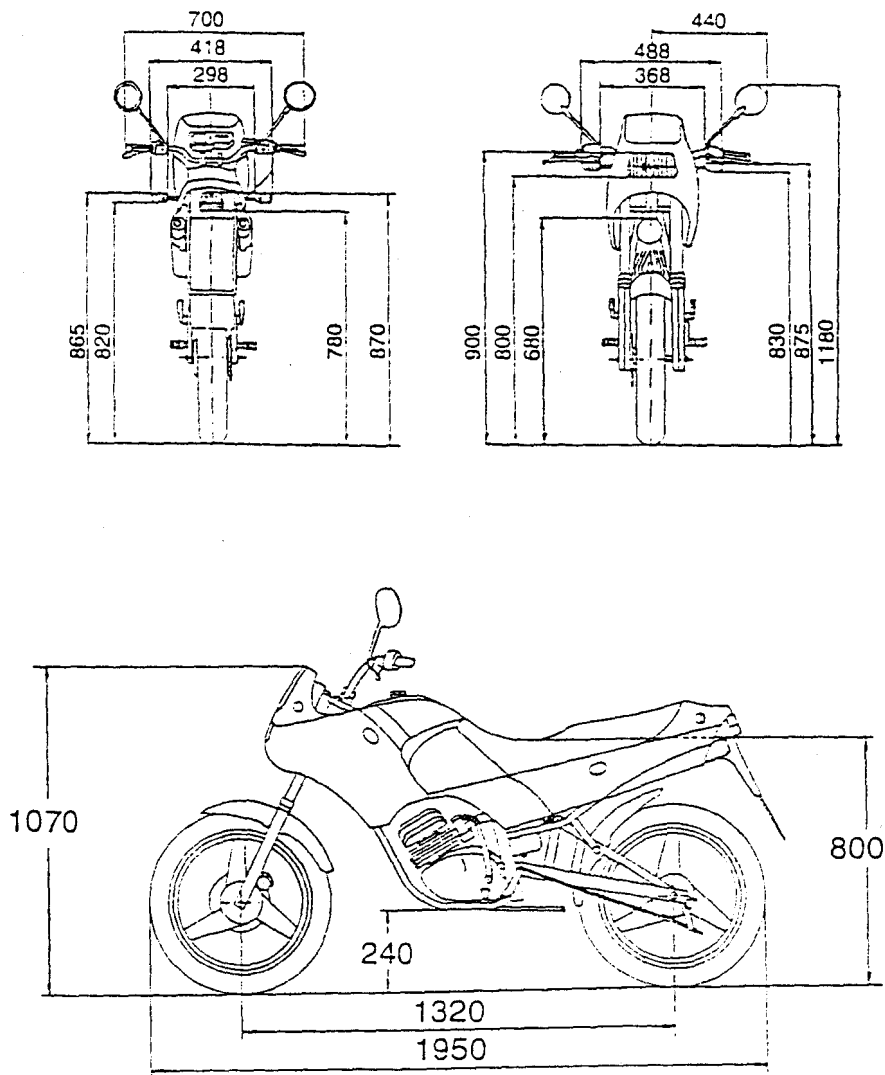
- Kerb weight 81 kg
- (with working liquids)
- Useful weight 180 kg
- Total weight 261 kg
- Number of places to sit 2

**Maximum speed**

65 km/h

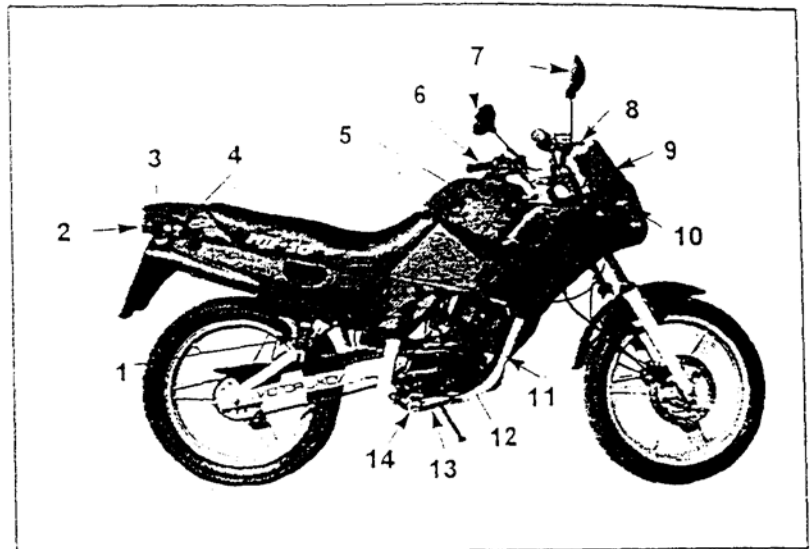
85 km/h

**Dimensional Drawing**

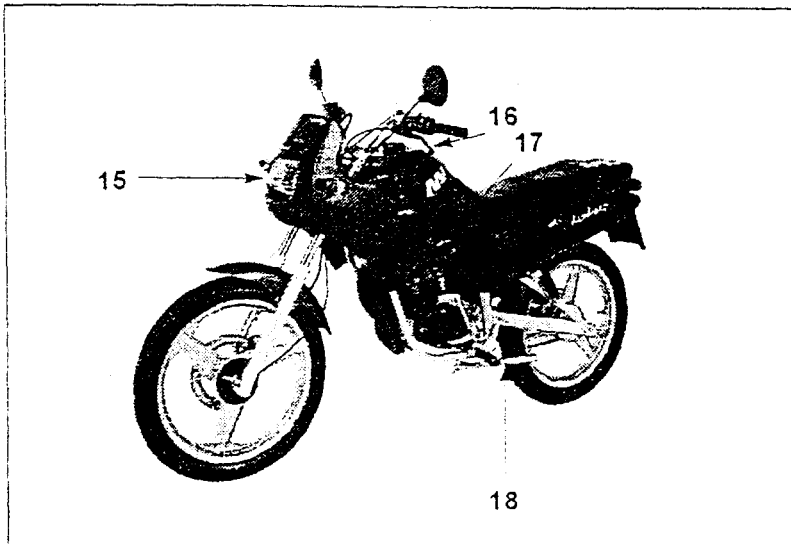


**Figure 2 Motorcycle Description**

- 1 - Rear foot rest
- 2 - Rear light
- 3 - Oil tank
- 4 - Rear direction light
- 5 - Fuel tank
- 6 - Clutch lever
- 7 - Rear-view mirrors
- 8 - Brake lever
- 9 - Front bonnet
- 10 - front direction light
- 11 - Engine
- 12 - Carburetter
- 13 - Rear brake lever
- 14 - Front foot rest



**Type. ACS, ACP, SC**



- 15 - Front headlight
- 16 - Clutch lever
- 17 - Fuel cock

**Type. AKS. AKP. SK**



## 4. Technical Description

The motorcycle is designed for operation on roads, but its design also enables to use it in a light terrain.

The 50 ccm engine is carried by the cradle-shaped double frame welded from steel sections (round, square and rectangular cross sections), which design ensures high overall stiffness of the motorcycle and guarantees safe drive.

Fixed in the steering head, in front part of the frame there is a telescopic fork that bears the front wheel equipped with the hydraulic disk brake. Besides the front wheel, there are mudguard and tubular handlebars with clutch and brake control levers, switch body and gas grip fastened to the fork. There are rear-view mirrors attached to the handlebars. The headlight and direction lights are fastened onto the frame head in front part (front part of bonnet - only for SK model). There is a horn fastened onto the frame brace under the steering head. The 6.5 l fuel tank is fastened to the front part of the frame.

Two-stroke licenced engine SACHS, fastened in front lower part of the frame, is equipped with an oil pump for separated lubrication of engine for some selected types of the motorcycle.

The engine is equipped with a carburetter according to the particular motorcycle type, which is connected through the elastic coupling with the intake silencer with replaceable filter element. The motorcycles exhaust piping with the exhaust silencer is led under the left rear side. Under the engine there are a foot rest holder, rear brakes, parking stand, and bearing of the rear swinging fork that is mounted on the central springing unit. The rear part of the frame that bears lockable double-seat, rear mudguard with rear light, and plastic sides with direction indicators is bolted in the upper section of the front part of the frame. Under the double-seat there is a room where battery and other mandatory equipment are located.

Transmission of torque is realized from the engine through the multi-plate clutch in oil bath and secondary roller chain to the rear wheel gear. The gearbox enables to shift five gears forward.

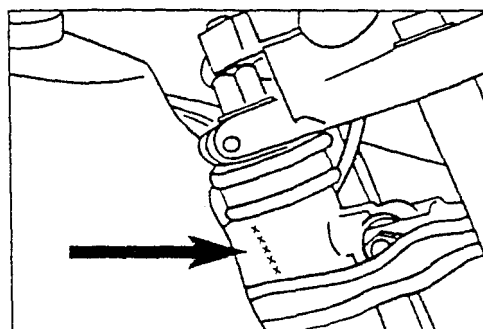
The electric installation is of 12 V, fed by the battery that is connected to the electrical network through the regulator after start of the engine.

### 4.1. Identification Marking

#### Type Identification:

**MJ 50 DANDY AKS**  
**MJ 50 DANDY AKP**  
**MJ 50 DANDY SKS**  
**MJ 50 DANDY ARS**  
**MJ 50 DANDY ARP**  
**MJ 50 DANDY SRS**  
**MJ 50 DANDY ACS**  
**MJ 50 DANDY ACP**  
**MJ 50 DANDY SCS**  
**MJ 50 DANDY AWS**  
**MJ 50 DANDY AWP**  
**MJ 50 DANDY SWS**

Figure 3



#### Frame Identification Number

- It is stamped on the right side of the steering head (Figure 3)

#### Motorcycle Identification Plate

- It is located on the right side of the frame front part, at the rear swinging fork suspension (Figure 3a)

Figure 3a

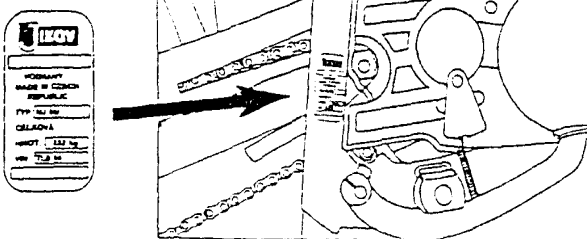
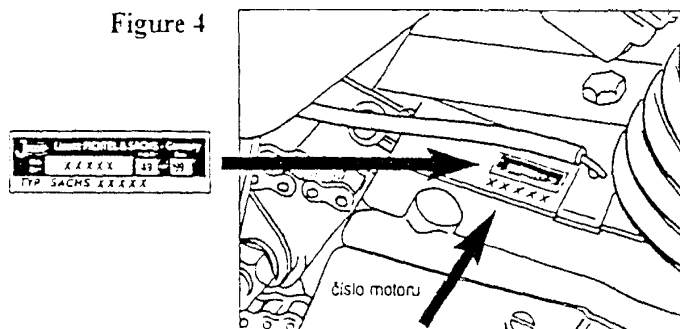


Figure 4



#### Identification Plate and Serial Number of the Engine

- Identification plate is fastened on the right side of the engine (Figure 4)
- Engine number is stamped on the right side of the engine (Figure 4)

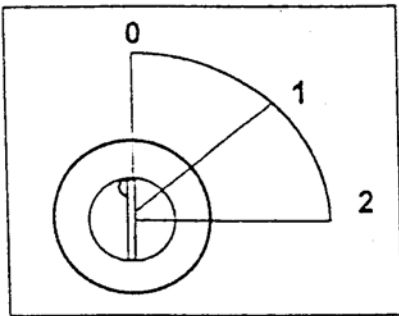


## 5. Familiarization with motorcycle before Drive

Before first drive it is necessary to familiarize himself with the motorcycle thoroughly and to carry out check of the whole motorcycle according to Section 6.

### 5.1 Electric Switch Control Switch Box

Figure 5



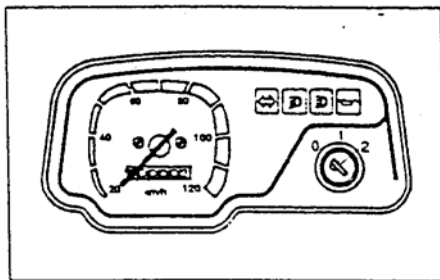
- ❑ The switch box controls ignition and lighting
- ❑ **Position 0** - Electric circuits are opened and it is possible to withdraw the key.
- ❑ **Position 1** - The electric circuits are closed, the clearance lights are on, and it is possible to start the engine.
- ❑ **Position 2** - The headlight and tail light are on.

### Pilot Lamps

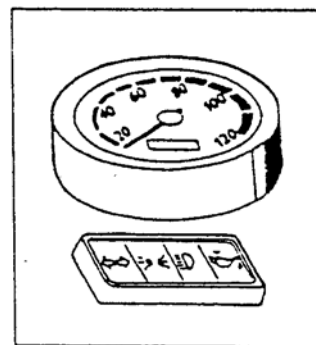
- ❑ The speedometer lighting - goes on after the start of the engine and indicates the clearance light function.
- ❑ Direction indicator pilot lamp - This lamp is flashing, when the direction light change-over switch is in the right or left extreme positions.
- ❑ Dimmed light pilot lamp - This lamp goes on after start of the engine and switching on the dimmed lights. and indicates the dimmed light function.
- ❑ Distance light pilot lamp - This lamp is on at use of the distance light.
- ❑ The pilot lamp of separated lubrication of the engine - This lamp indicates minimum amount of oil (0.5 lt) in the oil tank for separated lubrication of the engine.

Figure 6

Type: Bonnetted design

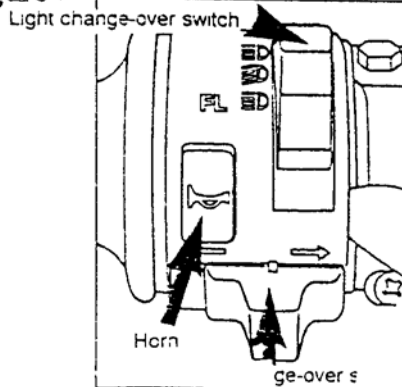


Type: Classic



### Switches on Handlebars

Figure 7



- ❑ The light change-over switch - serves for switching over the dimmed and distance lights. Its individual positions are shown on Figure 7
- ❑ The direction light change-over switch - serves for indication of turning on the right (extreme right position) and on the left (extreme left position). Do not forget to return it to the central position after the turning is completed.
- ❑ The horn - An acoustic signal sounds after pressing the horn's push-button.

## 5.2. Brake Control

Two independent brakes serve for safe stopping of the motorcycle. The machine is equipped with the disk brake on the front wheel, and the drum brake on the rear one

### 1. Front Brake Control

- ❑ The front disk brake is operated by right hand, using the lever located on the right side of the handlebars (See Figure 8).

### 1. Rear Brake Control

- ❑ The rear brake is operated by right foot through the lever under the foot rest on the right side of the motorcycle (See Figure 9).
- ❑ If the engine is running, the rear stop light goes on automatically at pressing the front or rear brakes.

Figure 8

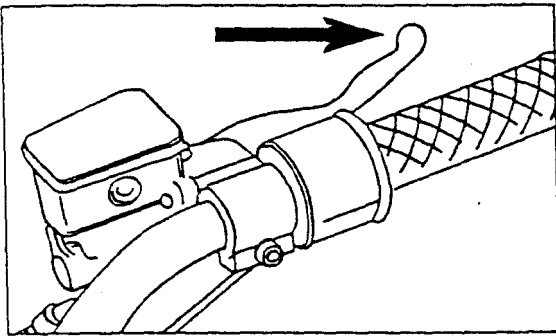
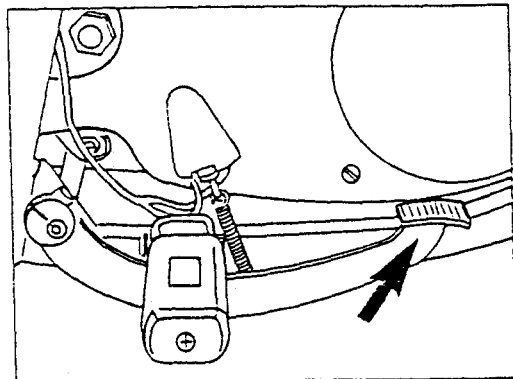


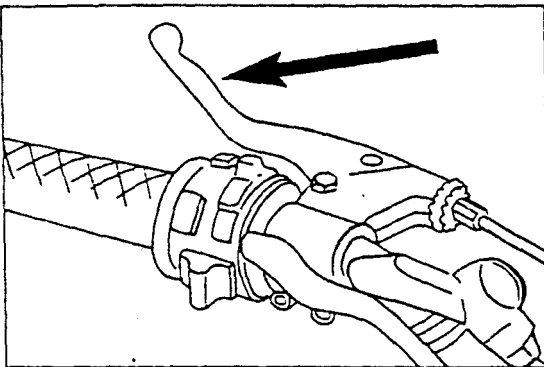
Figure 9



## 5.3. Clutch Control

The multi-plate oil bath clutch serves for setting the motorcycle into motion and gear shifting.

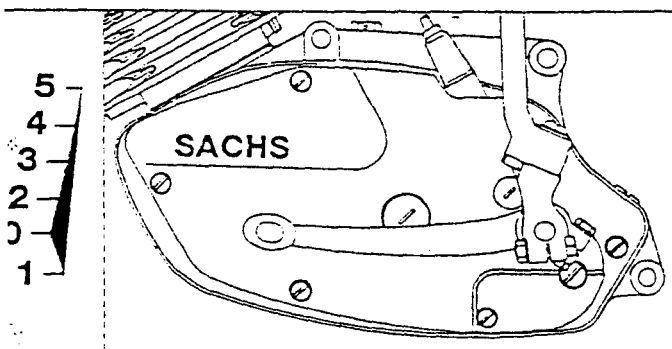
Figure 10



- ❑ The clutch is operated by left hand, using the clutch lever on the left side of the handlebars (Figure 10). For smooth setting the motorcycle into motion it is necessary to learn how to handle the clutch carefully. The clutch must be pressed down anytime you will shift the gear to eliminate the damage to the gearbox.

## 5.4. Gear Shifting

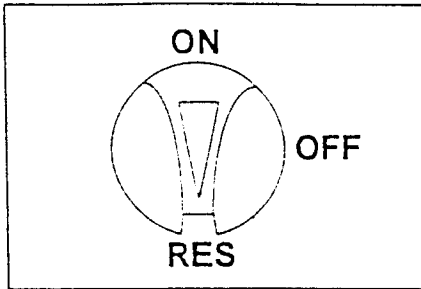
Figure 11



- ❑ The motorcycle is equipped with 5-gear gearbox and neutral between the first and second gears. The gear shifting is carried out by left foot, using the gear shift lever on the left side of the engine. At gear shifting it is always necessary first to press down the clutch lever, and then to shift the selected gear.
- ❑ The positions of particular gears are shown on Figure 11.
- ❑ Shift always the neutral after stopping.

## 5.5. Fuel Cock Control

Figure 12



- ❑ The fuel cock has 3 positions - open, closed, and reserve, and at the same time it cleans the fuel.

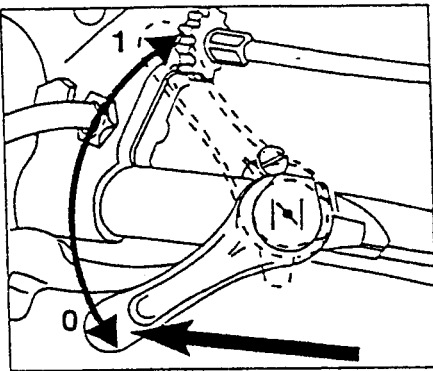
**OFF** - The cock does not let fuel flow through it in this position (Return always to this position after stopping the engine).

**ON** - In this position fuel flows into the carburettor, the position serves for normal operation.

**RES** - Use the reserve, when fuel ends during the drive; there is still 0.6 l of fuel in the reserve.

## 5.6. Choke Lever Control

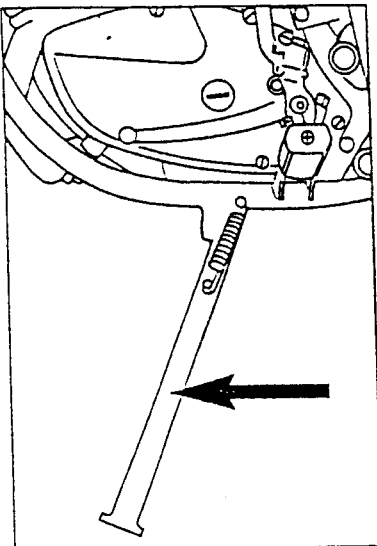
Figure 13



- ❑ The engine requires richer mixture for cold starts.
- ❑ The choke is operated by turning the lever located on the left side of the handlebars (Figure 13).
- ❑ Return the lever into its initial position after heating the engine.

## 5.7. Side Stand

Figure 14



- ❑ The side stand is fastened on the left side of the motorcycle frame and serves for the motorcycle parking.
- ❑ The stand is drawn down to its lower position, and the motorcycle is then put on it.
- ❑ When the stand is released, it returns back spontaneously to its initial position.

### WARNING!

The motorcycle must not be used for drive with its side stand in lower position. Should the stand not be return to its initial position before the drive, it could contact the road with resulting loss of control over the motorcycle.

## 5.8. Tool Box

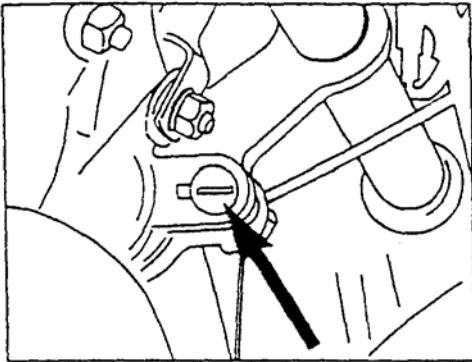
The tool box is accessible after unlocking and taking off the seat.

- ❑ To unlock the tool box, insert the key into the lock and turn it to the right. After withdrawal of the lock it is possible to take off the seat.
- ❑ Following basic equipment of the motorcycle is placed in the tool box:
  - wrench for sparking plugs, - handle - double-ended wrenches 13/16, 18/21, 8/10
  - socket wrench 6 - screwdriver - air pump.

### 5.9. Machine Locking

It is possible to secure the motorcycle against unauthorized use by locking the lock located on the right side of the steering head (Figure 15).

Figure 15



- ❑ Lock the machine by insertion of the key into the lock, turning the key to the right, insertion of the lock inside, turning the key to the left and its withdrawal.
- ❑ Unlock the machine similarly, but with withdrawal of the lock, which unlocks the steering beam.
- ❑ Store attached copies of the key carefully.

### 5.10. Working Liquid Refilling

#### 1. Fuel

#### For motorcycles without separated lubrication of the engine

(engines SACHS 50/5 AKF, AKF S, SACHS 50 S).

Open the fuel tank closure by its turning to the left, and refill the petrol and oil mixture (for better mixing first pour in oil and then petrol)

**Recommended petrol:** with minimum octane number 90, including leadless petrols.

**Recommended oil:** MOGUL TS, CASTROL Super TT, SHELL Super 2TX

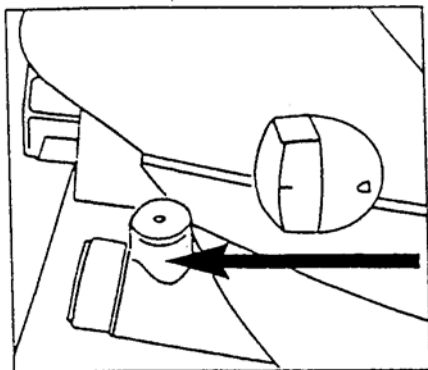
#### Mixing ration table:

Oil Type	Mixing ratio	
	for running-in up to -500 km	for normal operation
MOGUL TS	1:30	1:40
CASTROL Super TT SHELL Super 2TX	1 40	1:50

- ❑ The capacity of the whole fuel tank: is 6.5 lt, out of which 0.6 lt is separated as a reserve.
- ❑ If you do not tank petrol directly on a petrol station but prepare the petrol and oil mixture yourselves, please observe the following procedure:-
  - Store petrol and oil only in clean and closed vessels.
  - Do not use long stored petrol, it could be contaminated by water or dirty.
  - Use only absolutely clean funnels for pouring.
  - Do not pour in petrol higher than 1 cm under the upper edge of the tank.
  - If you overfill the petrol or pour it over the tank and engine at refuelling, dry carefully the affected places before starting the engine.

## For motorcycles with separated lubrication of the engine

(engines SACKS 50/5 AKF I, AKF SI).



- ❑ Open the fuel tank closure by its turning to the right and refuel the tank with the petrol prescribed.
- ❑ Open the oil tank closure (for separated lubrication of the engine) and refill the tank with the oil prescribed.

**Oil tank capacity:-** approx. 1.3 lt

**Recommended oil:-** Mogul TS,  
CASTROL Super TT,  
SHELL Super 2TX

- ❑ The capacity of the whole fuel tank is 6.5 lt, out of which 0.6 lt is separated as a reserve.

### WARNING!

For the first drive with a new motorcycle fill the fuel tank with 1 litre of the prescribed petrol and oil mixture in the ratio 1:30 (1:40), see Mixing Ratio Table. After use of this amount of petrol use only petrol without oil (for the types with separated engine lubrication).

Following warnings apply to all types of motorcycles

### WARNING!

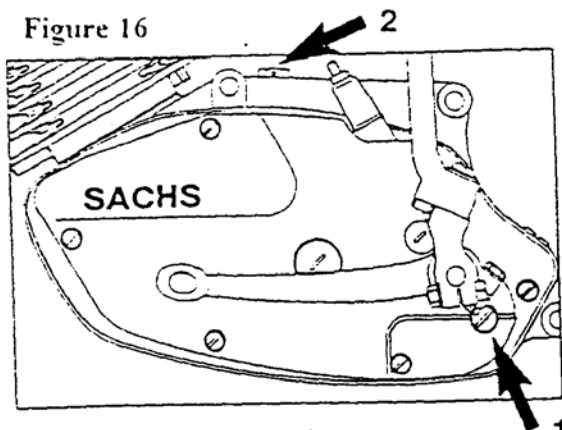
It is forbidden to refill petrol on the engine running and in closed and poorly ventilated rooms!

### WARNING!

The fuel tank closure ensures its venting and tightness at overtilting, therefore it is forbidden to make any incompetent action on it!

## 2. Engine Oil Fill

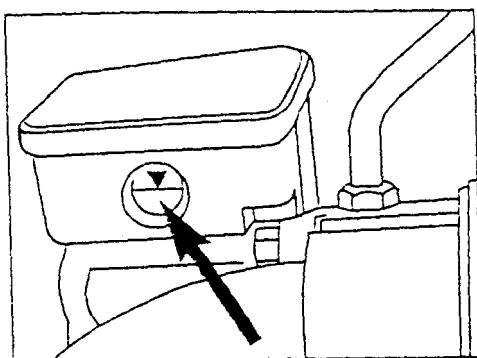
Figure 16



- ❑ Stand the motorcycle on a horizontal surface and unscrew the oil check plug (Figure 16). If oil does not flow out, refill the oil tank (See Section 8.4).
- ❑ Unscrew the filling hole plug and fill the oil tank with the prescribed oil (See Section 8.4) until the oil flows spontaneously out of the check hole. Screw in the both plugs and tighten them properly.

## 3. Front Hydraulic Brake Fill

Figure 17



- ❑ The brake fluid tank is located on the right side of the handlebars. The fluid level is maintained within the lower and upper edge of the check hole.
- ❑ Refilling and replacement of the fluid. (See Section 8.12)

## 6. Motorcycle Check Before Drive

### 6.1. Brake Check

#### 1. Brake Lever and Brake Pedal

- ❑ Check correct functions of the front brake lever and rear brake pedal. If the functions are not acceptable, make necessary adjustments (see Section 8.12, 8.13).

#### 2. Brake Fluid

- ❑ Check the amount of the brake fluid in the tank on the right side of the handlebars. In case of need refill it, and check visually tightness of the braking system.  
(See Section 8.12.)

### 6.2. Clutch Check

- ❑ Check the clutch lever clearance and make sure that the lever works properly. If not, make necessary adjustment. (See Section 8.1 1.)

### 6.3. Gas Grip Check

- ❑ Turn the grip a bit and make sure that it returns into its initial position after its release. Ask special service immediately for the gnp adjustment, if need be.

### 6.4. Chain Check

- ❑ Before each drive check condition and tightening of the chain. In case of need adjust and grease it (see Section 8.17.)

### 6.5. Tyre Check

- ❑ Check the pressure in the tyres. The tyre pressure must be adapted to the motorcycle load as follows:

- load up to 90 kg	front tyre	180 kPa	26 psi
	rear tyre	230 kPa	33 psi
- load above 90 kg	front tyre	230 kPa	33 psi
	rear tyre	280 kPa	41 psi
- ❑ Check condition of the tyres. If the depth of pattern on the tyre centre is less than 1 mm or if the tyre side is cracked or otherwise damaged, replace the tyre, best of all in the special service.

**Use only the tyres approved for this type of motorcycle. Other tyres change characteristics of the machine control, and in that case manufacturer is not responsible for any damage due to use of these tyres.**

#### Front tyre:

MICHELIN 2.75" x 17"  
SAVA 2.5" x 17"  
METZELER 2.75" X 17"

#### Rear tyre:

MICHELIN 3.00" x 17"  
SAVA 2.75" x 17"  
METZELER 3.00" x 17"  
BARUM\* 90/90 x 17"

(\* only combined with the tyre SAVA on the front wheel)

### 6.6. Wheel Check

- ❑ Always check the wheels before drive, and in case of any failure contact the special service.

**Do not try to make any repair on the wheel. If the wheel is cracked or deformed, it must be replaced by a new one.**

- ❑ The wheel should be balanced after each mounting of the tyre. Unbalanced wheel causes bad controllability of the machine and shortens service life of tyres.

### 6.7. Electric Installation Check

- ❑ Check correct functions of headlight, rear and stop lights, direction indicators, and all pilot lamps.

## 7. Driving the Motorcycle

- ❑ The driver must own a licence for driving small motorcycles and meet all requirements according to valid regulations and the highway code.
- ❑ When driving it is unconditionally necessary for the driver and pillion-rider to use protective crash helmets.
- ❑ Before drive you are obliged to check readiness and technical condition of your motorcycle to make sure that it meets relevant highway code (see Section 6.).

### 7.1. Motorcycle Starting

- ❑ Turn the fuel cock into the ON position.
- ❑ Lift up the side stand.
- ❑ Turn the key into the first position and engage the neutral (Figure 18).

Figure 18

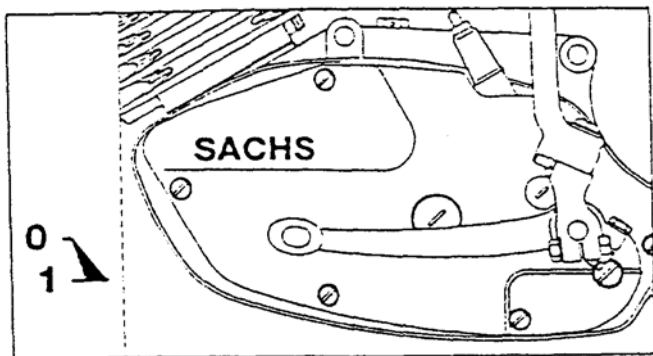
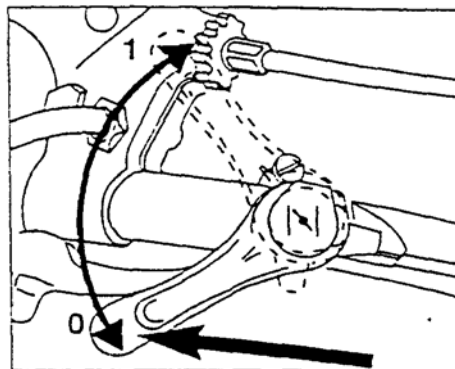


Figure 19



#### Cold Start

- ❑ Open the choke fully and let the gas grip in the zero position. Start the engine by quick, smooth stepping on the starting lever of the engine. The starting lever returns automatically by a return spring.
- ❑ After start of the engine and its heating to the working temperature return the choke into its original position (Figure 19).

#### Hot Start

- ❑ You need not use the choke to start the hot engine.

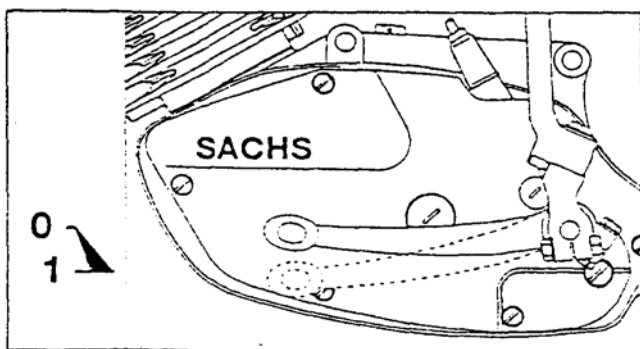
#### **WARNING!**

**Never start the engine or let it run in a closed room. Exhaust gases are poisonous and may cause loss of consciousness or even death in a very short time.**

**Always lift up the side stand before any drive. If it is not fully up, it can cause serious accident at turning.**

### 7.2. Motorcycle Setting into Motion

Figure 20



- ❑ Turn the switch box key into the second position (the lights are on).
- ❑ Press the clutch lever, engage the first gear (put your foot down on the gear lever until its lower extreme position) Figure 20.
- ❑ Increase the engine speed by the gas grip partly and simultaneously begin to release slowly the clutch lever (see Section 5.3 )
- ❑ Approximately in the last third of the lever travel the clutch is engaging, and after its full release the motorcycle begins to move.
- ❑ When the motorcycle is moving, its speed is controlled by the gas grip and by changing other gears (see Section 5.4.).

**Correct placing of loads on your motorcycle is important for its control, braking, and other manoeuvring, and it can affect the safety of drive. Do not transport freely attached things that could move during drive and change the balance suddenly.**

**Never overload the motorcycle; take care that the overall weight of the load, driver, and pillion-rider, equipment (aerodynamic elements, seat bag, if approved for this type of motorcycle) does not exceed the maximum permissible load of the motorcycle.**

### **7.3. Motorcycle Stopping**

- ❑ Release the gas grip, press down the clutch lever, and brake using one or both brakes according to the relevant conditions until the motorcycle stops.
- ❑ Engage the neutral and release the clutch lever. If you also want to stop the engine, turn the key in the switch box to the **first position**.
- ❑ Close the fuel cock - position **OFF**.
- ❑ When parking, always withdraw the key from the switch box and lock the motorcycle.

### **7.4. Engine Running-In**

**The engine running-in influences its output and life significantly. Therefore you are asked to study the following data carefully.**

- ❑ Use the fuel mixture prescribed by the manufacture for the engine running-in (see Section 5.10.).

#### **0 to 500 km**

- ❑ After each hour of drive stop the engine and let it cool down for approx. 10 minutes.
- ❑ Do not accelerate quickly, nor load the motorcycle engine with full output; use only 1/2 turn of the gas grip.
- ❑ Do not maintain the drive speed constant long, change it to change the speed of engine.

#### **500 to 1,000 km**

- ❑ Do not drive long with more than 3/4 turn of the gas grip.

#### **WARNING!**

**Do not forget to replace the gear oil after completion of 1,000 km!**

#### **over 1,000 km**

- ❑ The motorcycle can be used with its full power after 1,000 km.

#### **WARNING!**

**In case of any failure of the engine during its running-in contact the special service immediately!**

## **8. Adjustment and Maintenance**

To maintain the motorcycle in safe and proper technical condition, it is necessary to check, adjust, and lubricate it regularly. The lubrication and maintenance table serves as a basic instruction for the regular maintenance. The maintenance must also take into account the method of use, and therefore it is necessary to schedule the regular maintenance intervals with regard to it.

On following pages you will find the most important data related to the regular check of the motorcycle.

**If you have not special knowledge of motorcycles, you are recommended to have all the work made by a special service.**



## 8.1. Lubrication and Maintenance Schedule

Work Description and Scope	Before Putting into Operation	After every 1,000 km	3,000 km	6,000 km	In Case of Need
<b>Screws and nuts</b> Tighten all screws and nuts (See Section 8.2.)	x	x			
<b>Driving chain</b> Check tightening of the chain. Clean and grease it by the spray for chains. (See Section 8.17. & 8.18. )		x			
<b>Brake adjustment</b> <u>Brake lining</u> - Check the brake lining. (take care of minimum thickness of the lining)				x	
When the brakes work incorrectly, check the function of hand/foot brake and make required adjustment. Grease joints and cables.				x	
Replace worn out, mechanically damaged or oiled lining.				x	
<u>Brake fluid</u> Check of the state of the break fluid and its replacement, if need be. (See Section 8.12_, 8.13)	x Every	x 2 years			
<b>Rear wheel swinging fork</b> Check its bearing - without clearances		x			
<b>Gear oil</b> Check the amount of oil and refill it, if need be		x			
<b>Oil Replacement</b> 400 ccm of gear oil (See Section 8.4., 8.5.)			x		
<b>Sparking plug</b> Check of the electrodes spacing and overall condition of the plug. Replace it, if need be. (See Section 8.9.)				x	x
<b>Exhaust silencer and paper filter</b> Clean the intake paper filter. Replace it, when to dirty. (See Section 8.7.)			x		x
<b>Speedometer drive</b> Grease the speedometer drive (on the wheel axis) SHELL RETLNAX-A				x	
<b>Bowden cables</b> Lubncate the cables with thin oil			x		
<b>Fuel screen in the carburetter</b> Clean the fuel screen by petrol and blow it through by pressure air. In case of damage replace by a new one.			x		x
<b>Fuel cock</b> Clean the fuel cock screen and blow it through by pressure air. (See Section 8.6.)					x
<b>Carburetter</b> Clean individual parts of the carburetter (See Section 8.6.)				x	x
<b>Exhaust silencer decarbonization</b> Remove the oil carbon from the exhaust piping end. (See Section 8.25.)				x	
<b>Ignition check</b> Have the check made in a special service. (See Section 3.10.)				x	

Work Description and Scope	Before Putting into Operation	After every 1,000 kni	3,000 km	6,000 km	In Case of Need
<b>Clutch and its adjustment</b> Check its function and adjust or replace it, if need be. (See Section 3.11.)				x	
<b>Telescopic fork</b> Functional check or replacement, if need be. (See Section. 8.21.)					x
<b>Steering bearings</b> Check and replacement, if need be. (See Section 8.22.)					x
<b>Wheel bearings</b> They require no maintenance. If there is a clearance in the bearings, replace them. <b>Have them replaced in a special service.</b> (See Section 8.23.)					x

## 8.2. Torques

Use a torque wrench for tightening the screws and nuts. It is recommended to make occasionally the check of tightening, especially before a long drive. Check always torques at mounting or dismantling individual parts.

### Torque Tables

Screw	Torque
M 6 mm	8-12 N.m
M 8 mm	18-28 N.m
M 10 mm	40-60 N.m
M 12 mm	70-100 N.m
M 14 nun	110-160 N. m
M 16 mm	170-250 N.m

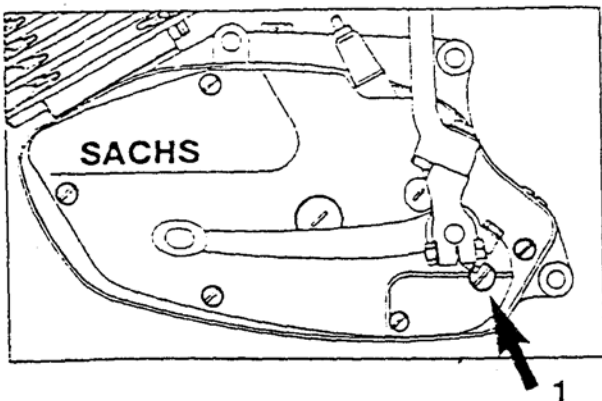
Engine drain plug	20-25 N.m	Rear brake lever screw	6-10 N.m
Sparking plug	15-20 N.m	Central springing unit	
Front wheel axle nut	35-40 N.m	screws	35-40 N.m
Front wheel axle socket screw	15-20 N.m	Brake braket screws	
Rear wheel axle nuts	50-60 N.m	upper	20-25 N.m
Swinging fork axle nut	30-35 N.m	lower	14-15 N.m
Lower beam screw	20-25 N.m	Handlebars Yoke screws	15-20 N.m
Upper beam screws	15-20 N.m	Brake hose screws	17-18 N.m
Engine bearing		Cylinder head nuts	10-12 N.m
Socket screw M8x53	10-15 N.m	Exhaust flange bolts	10-15 N.m
Socket screw - M8x100	25-30 N.m	Screws for plastic	3.5 - 4 N.m

### 8.3. Table of Lubricants Used

		<b>Oil</b> (Viscosity Class)	<b>Grease</b>
Gear box	SAE 80 W API GL-4	MOGUL TRANS 80 TRYSK GYROL 80W/90 MADIT PP 80 CASTROL EP 80 SHELL Spirax EP (MA)	
Bowden cables		MOGUL TS	
Lever pins	SAE 80 W API GL-4	MOGUL TRANS 80 TRYSK GYROL 80W/90 MADIT PP 80 CASTROL EP 80 SHELL Spirax EP (MA)	
Speedometer drive Gas grip			MOGUL LA 2 SHELL Retinax A AGIP GREASE 30
Front fork	SAE 10W-30	M 3 ADX CASTROL TQ Dexron	
Rear springing unit		AMG 10 CASTROL HYSIN AWS 10	
Secondary chain		CASTROL Super Ketten spray TEXACO Ketten spray	
Engine lubrication TSC-1		MOGUL TS CASTROL Super TT SHELL Super 2TX	

### 8.4. Gear Oil Level Check

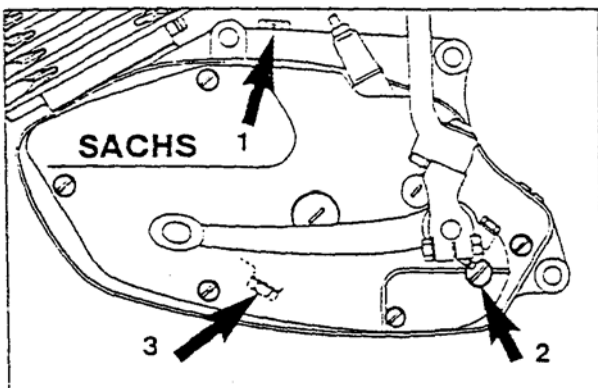
Figure 21



- ❑ Stand the motorcycle vertically so that it is not deflected to one side. Its deflection will cause incorrect measurement.
- ❑ Unscrew the oil check plug (1), and check if the oil reaches minimally up to the lower edge of the check hole.
- ❑ If the level is lower, refill the relevant oil.

### 8.5. Gear Oil Replacement

Figure 22



- ❑ Start the engine and let it heat up for 1 to 2 minutes.
- ❑ Place an oil vessel under the engine.
- ❑ Unscrew the filling plug (1), check plug (2), and drain plug (3), and let the oil get out (Figure 22).
- ❑ Screw in the drain plug and tighten it. The torque is 20 N.m
- ❑ Refill 0.4 lt of recommended gear oil into the filling hole.
- ❑ After refilling the gear box check, if oil does not leak out of the drain plug or oil level check plug.

## 8.6. Fuel Cock Cleaning

The fuel cock has a built-in filter element that cleans fuel before the carburettor inlet. If it would have been clogged, the fuel could not get into the engine in required amount.

### Type: Bonneted design

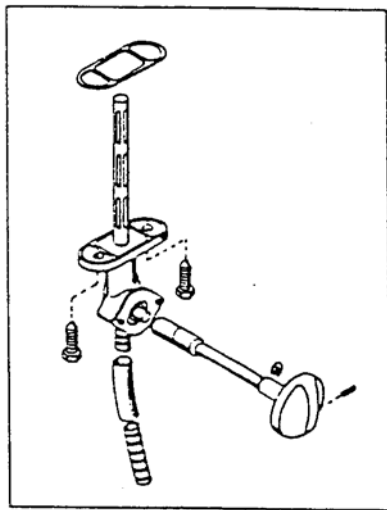
- ❑ Disconnect the electric installation from the front direction lights, and dismantle the lights by releasing and unscrewing the fastening nuts.
- ❑ Withdraw the split pin from the connecting shaft of the fuel cock and disconnect the connecting shaft.
- ❑ Dismantle the front bonnet by unscrewing of four screws. Unlock and take off the double seat and dismantle rear „L" and „R" sides. Then unscrew the tank cap and unscrew 2 nuts that fasten the tank cover to the frame, and after it remove the cover from the tank.

### Type: Classic

- ❑ Disconnect the electric installation from the front direction lights, and dismantle the lights by releasing and unscrewing two nuts.
- ❑ Withdraw the split pin from the connecting shaft of the fuel cock and disconnect the connecting shaft.
- ❑ Unlock and take off the double seat and dismantle rear „L" and „R" sides. Then unscrew the tank cap and unscrew 2 nuts that fasten the tank cover to the frame, and after it remove the cover from the tank.

Note: Following operations are identical for both types

Figure 23



- ❑ Discharge fuel from the tank.
- ❑ Dismantle the fuel cock out of the tank in the following way:-
  - Set the cock control to **ON**
  - Unscrew the screws M6 with the control pull rod bracket
  - Remove the fuel cock
- ❑ Clean the fuel cock by petrol in various positions of its setting and blow it through by pressure air.
- ❑ Mount the fuel cock in reverse order.

Check the packing, and replace it, if need be.

## 8.7. Air Filter Cleaning

- ❑ Disconnect electric installation from the rear direction lights and dismantle the lights by unscrewing two nuts with following removal of the lights. Take off the rear cover.
- ❑ Dismantle the right rear side by releasing the nuts which fasten it to the front bonnet, and then disconnect the side from the bolt and withdraw it backwards.
- ❑ Dismantle the filter cover, remove the filter element and clean it by pressure air. If it is too dirty, replace it by a new one.
- ❑ Install the filter element back in such a way that contact surfaces fit properly to ensure their tightness.
- ❑ Clean the air filter in the intervals recommended by the motorcycle's manufacturer. At operation in a dusty environment shorten these intervals.
- ❑ Perform assembly in the reverse order.

### WARNING!

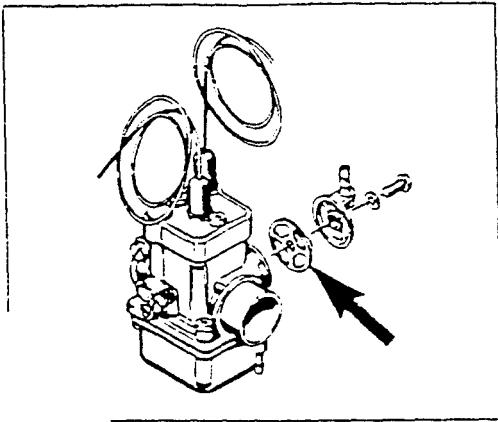
**Never operate the engine without the air filter**

## 8.8. Carburetter Check

The carburetter is an important component of the engine, and its adjustment requires special skills and special service equipment. Most of the operations at adjusting would be carried out in a special service.

### Check of the Carburetter Fuel Screen

Figure 24



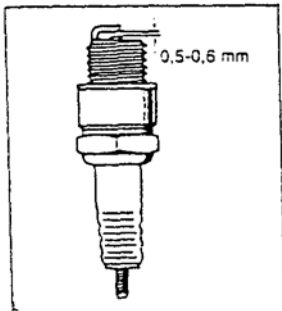
- ❑ In case of need or after 6,000 km it is recommended to carry out the check of the fuel screen in the carburetter.
- ❑ Dismantle the screen cover and remove the screen. Clean the screen by fuel and blow it through by pressure air.
- ❑ If it is too dirty or damaged, replace it by a new one. The fuel screen assembly is carried out in the reverse order.

### WARNING!

Any incompetent action in the carburetter can result in decreased power, increased consumption, or even damage to the engine.

## 8.9. Sparking Plug Check

Figure 25



- ❑ Unscrew the sparking plug and check, if its electrodes are not fouled by a layer of carbon or burnt.
- ❑ Clean the sparking plug electrodes by a smooth wire brush: at big fouling replace the plug by a new one.
- ❑ When installing the plug back, check the electrode spacing and adjust it, if need be.

### Recommended sparking plug:

Engine type	<b>SACHS 50/5 AKF, SACHS 50/5 AKF I</b>	<b>SACHS 50 S</b>
	<b>SACHS 50/5 AKF S, SACHS 50/5 AKF SI</b>	
	BRISK N 17	BRISK L N 14
	BOSCH W 5 BC	BOSCH W 3 A
	CHAMPION L - 81	CHAMPION L - 78
	NGK B 6 HS	NGK B 8 HS

**Electrode spacing:** Sparking plug BOSCH 0.5 to 0.6 mm

**Sparking plug torque:** 15 to 20 N.m

## 8.10. Ignition

The motorcycle is equipped with contactless ignition which check and/or repair requires a service equipment. At an ignition failure contact the special service.

## 8.11. Clutch Check and ,Adjusment

Any damage to the Bowden cable causes corrosion of the cable and stranded wire, which could prevent from its motion. It can result in dangerous situations. Therefore, if the cable is damaged mechanically, replace the whole cable immediately by a new one.

If the clutch stranded wire hardly moves in the Bowden cable, lubricate the cable with thin oil. If the strand wire still is not released, replace the whole cable or contact a special service and have it repaired.

### Clutch Cable Replacement

- ❑ Release the stranded wire at the clutch lever on the handlebars.
- ❑ Unscrew the clamping screw on the right cover of the engine block (Figure 26).
- ❑ Lift the clutch lever (1) by a screwdriver (Figure 27). Press down the pull stranded wire, unhang it, and withdraw it upwards. Remove its end terminal through the opening in the engine block cover.

Figure 26

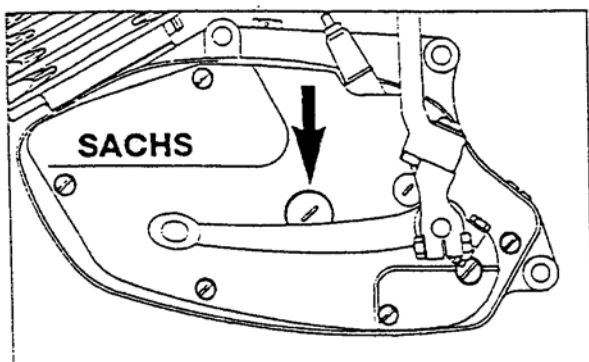
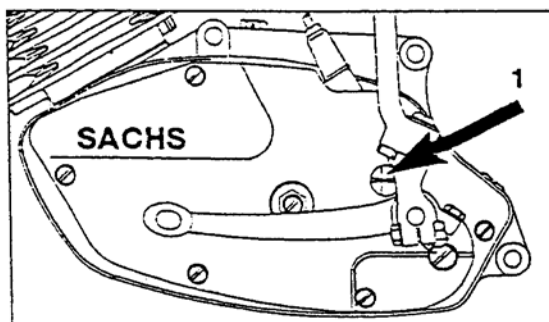


Figure 27



- ❑ Insert the pull stranded wire through the opening in the engine block cover, lift up the clutch lever, and hung the pull stranded wire.
- ❑ Connect the stranded wire to the clutch lever on the handlebars.

### Clutch adjustment (Figure 28)

- ❑ Release the nut (1), unscrew the adjusting screw (2).
- ❑ Unscrew the adjusting screw on the clutch lever on the handlebars to the stop.
- ❑ Check if the clutch lever (1) contacts the engine block cover (see the arrow).

Figure 28

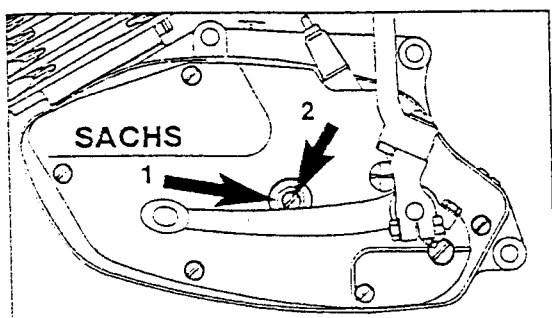
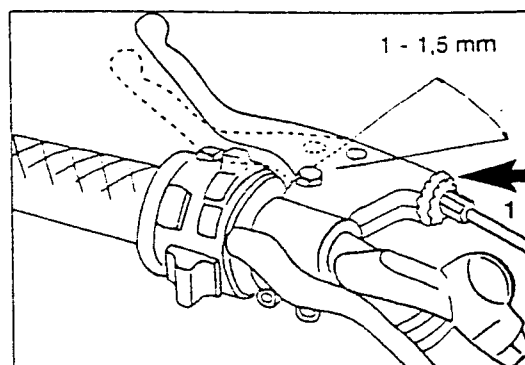


Figure 29



- ❑ Adjust the clearance of the clutch lever by the adjusting screw (1) on the handlebars (Figure 29)  
Clutch lever clearance on the handlebars: 1 to 1.5 mm
- ❑ Secure the adjusting screw at the clutch lever on the handlebars by the lock nut.
- ❑ Screw in the adusting screw (3) up to stop, then release it by 1/3 turn and secure by the lock nut.
- ❑ Screw in the locking screw

## 8.12. Front Wheel Brake Check and Adjustment

It is recommended to have the following work made by a special service.

For the front wheel hydraulic brake, the brake plates are self-adjusting. Due to wet, dirty or wear the brake plates can become hardly movable in the disk brake yoke body after long use.

Clean the brake plates and contact surfaces in the yoke body. Check the thickness of the lining on the demounted plates:

- minimum thickness of the lining (including supporting plate): 2.5 mm

After check or repair made install the plates back.

Replace damaged or worn out plates by new ones.

- ❑ Regular inspection of the condition of the brake fluid in the tank is important. If there is found a less amount of the brake fluid in the tank than it would be, it is probable that it leaks due to an untightness in the braking circuit. Check all connections and hose for tightness.
- ❑ If brake disk is stained by the brake fluid it is probable that the piston packing ring in the brake yoke was damaged.

On each disassembly of the brake plates check the pistons in the brake yoke for easy motion.

Figure 30

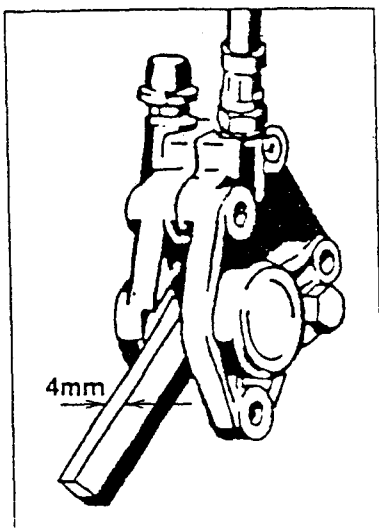
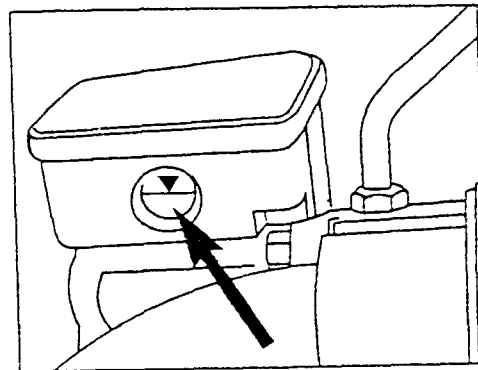


Figure 31



After repair of the front brake system it is necessary to carry out its deaeration!

- ❑ Release the locking sheet of the brake yoke upper fastening bolt nut and release the bolt. Unscrew the lower fastening bolt and remove it with all distance washers. Turn the yoke in such a way that the deaerating screw will be in the highest position.
- ❑ Insert a washer between the brake linings which thickness corresponds to the brake disk thickness (Figure 30). - **Brake disk thickness: 4.5 mm**
- ❑ At deaeration of the front wheel brake, first remove the closing cap from the deaerating screw and put the deaerating hose on it. Immerse the other end of the hose in a vessel filled partially with the brake fluid
- ❑ Then release the deaerating screw.
- ❑ Press down the brake lever, and slowly release the venting screw, and again tighten it before you release the brake lever to its original position. Repeat the operation until the brake fluid without bubbles flows out of the deaerating screw. During deaeration check the amount of fluid in the tank and refill it, if need be. After the brake deaeration, fill the fluid up to the specified marks, and then close the lid on the tank (Figure 31).

### WARNING!

Be careful at refilling - the brake fluid is aggressive against varnish!

Air in the hydraulic brake system affect the brake function due to the brake fluid refilled late or due to other leaks.

Have the brake repaired rather by a special service.

## 8.13. Rear Wheel Brake Check and Adjustment

### Rear Wheel Brake Maintenance

It is recommended to have the following operations made by a special service.

- ❑ The brake maintenance requires only its regular adjustment and cleaning and check of its lining thickness and condition (roughly once or twice a year, or at worse effect of the brake)
- ❑ Cleaning will remove dirty; the abrasive wear is removed out of the drum and lining by smooth - abrasive cloth.

**The brake lining must not be oiled or soaked with wate.**

**At cleaning by pressure of water take care that water cannot get into the wheel bearings or brake drum.**

### Brake Lining Check

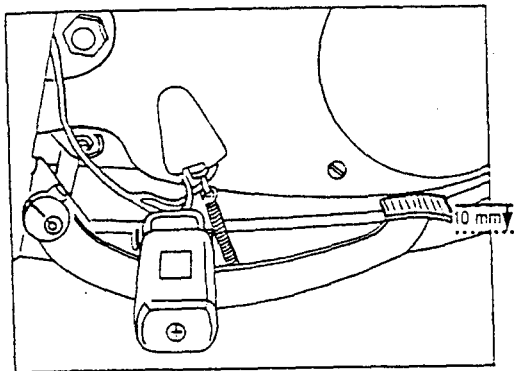
- ❑ Disconnect the control rod of the brake at check of the brake lining thickness, dismantle the rear wheel (see Section 8.20.), and remove the brake cover with brake shoes out of the wheel drum.
- ❑ The thickness of the brake lining fastened on the shoes is min. 0.5 mm. For the new lining the thickness is 2.5 mm.
- ❑ The mounting is carried out in the reverse order, with following adjustment of the rear wheel brake.

### Rear Wheel Brake Adjustment

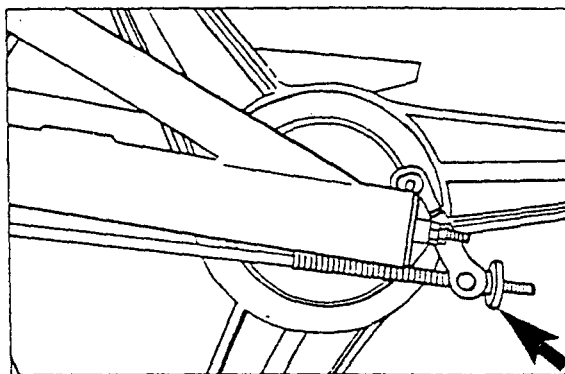
During operation the wear of the brake shoes results in increased dead travel of the pedal.

- ❑ The recommended dead travel on the foot brake lever is **30 mm with the motorcycle unloaded.**
- ❑ At maximum loading of the motorcycle (180 kg) the dead travel of the foot brake lever changes to the value of **10 mm** (Figure 32).

**Figure 32**



**Figure 33**



**Not observing these values it could happen that the rear wheel will brake at springing.**

**The adjustment must always be carried out after dismantling or mounting the rear wheel or rear brake rep air.**

- ❑ The adjustment is carried out on the rear wheel by turning the knurled nut on the rear wheel brake pull-rod (Figure 33).

## 8.14. Excessive Effect of Brakes

At long parking of the motorcycle, especially in the winter months, the volume of brake lining increases due to moisture. Thus failure results in an excessive braking effect even at small pressing of the brake pedal.

Therefore it is recommended to press down the brake lever first carefully at drive and with 2nd gear engaged (gas grip in 1/2 position), and then more to heat up and dry the brake lining.



### 8.15. Rear Stop Light Switch

The stop light switch must be set in such a way that the stop light goes on immediately at the start of the brake control lever travel.

- ❑ It is not possible to adjust the stop light switch. Replace it, if need be, or contact the special service.

### 8.16. Front Stop Light Switch

- ❑ The stop light must go on immediately. when pressing the hand lever of the front wheel brake.
- ❑ It is not possible to adjust the stop light switch. Replace it, if need be, or contact the special service.

### 8.17. Chain Tightening

- ❑ It is necessary to check the chain tightening during operation.
- ❑ Before the chain tightening check or adjustment, turn the wheel several times. During this turning check the chain tightening and find the point, where the chain is tightened most of all. (Carry out its adjustment in this position.)
- ❑ At the check the motorcycle must stand vertically to the ground, with both wheels on it, and without a driver.
- ❑ It must be possible to slag the chain within 20 to 30 mm with the unloaded motorcycle. If the sag exceeds 30 mm, adjust it (Figure 34).

Figure 34

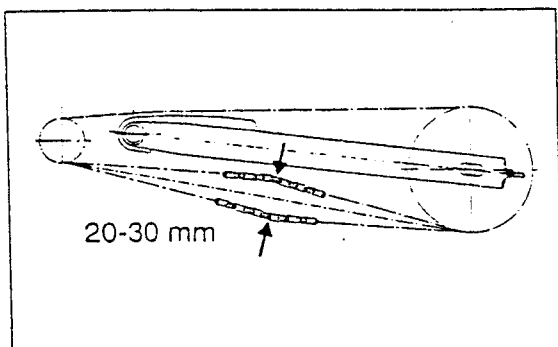
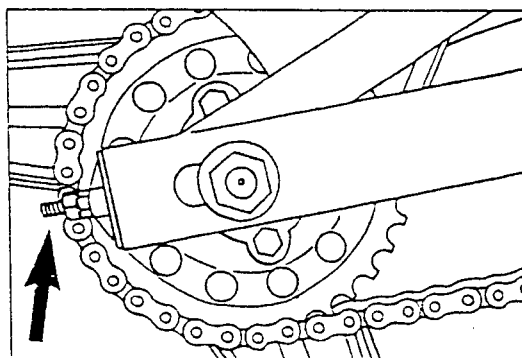


Figure 35



#### Tighten the chain as follows:

- ❑ Release the wheel axle nut on the right side.
- ❑ Shift both chain tighteners simultaneously (e.g. by 1/2 of nut turns) to maintain the wheel trace (Figure 35).

#### Excessive tightening of the chain will overload the engine and other movable parts.

- ❑ After the adjustment check the mutual position of front and rear wheels by means of a straight bar (The bar is attached onto the front and rear wheels). Make a correction, if need be, by the chain tighteners.
- ❑ After the adjustment tighten properly the tighteners locking nuts as well as the wheel axle nuts.
- ❑ The rear wheel brake must be readjusted (see Section 8.13.).

## 8.18. Chain Cleaning

- ❑ First dismantle the right cover of the engine.
- ❑ Release the wheel axle nut and chain tighteners. Then disconnect the chain coupling link (Figure 36). withdraw the chain from the engine block, and take it out of the gear by moving the wheel a slight amount.
- ❑ Wash the chain in kerosene or petrol to remove all mechanical impurities and lubricants. Clean it using a brush, wire brush, with moving the chain links Until they are clean and freely movable.
- ❑ Put the dry chain into the heated special grease for chains. When the grease bath has the required temperature, move the chain in such a way that the grease could get even onto the inside working surfaces of individual chain links. Then remove the chain, let it drip and cool down.
- ❑ Mount the chain in reverse order. See Section 8.17. for tightening of the chain.

The chain is connected with the coupling link. Take care that the closed end of the closing spring of the coupling always points out in the direction of the chain motion (Figure 37).

Figure 36

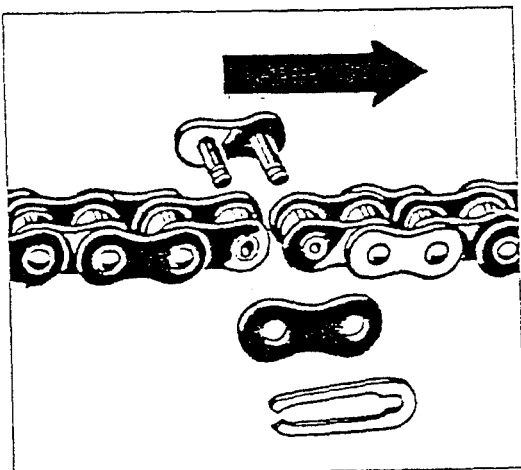
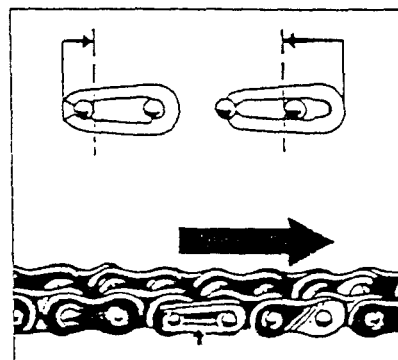


Figure 37



## 8.19. Front Wheel Mounting and Dismantling

- ❑ Dismantle the front wheel axle nut and release the forcing-off socket screw of the left glider. Withdraw the wheel axle using a pin  $\varnothing$  6 mm.
- ❑ Withdraw the front wheel downwards, remove the distance rings and speedometer drive assembly.
- ❑ Mounting is carried out in the reverse order.

Tighten the forcing-off screw only after the multiple pressing the telescopic fork. At mounting take care of correct position of the distance ring.

## 8.20. Rear Wheel Mounting and Dismantling

- ❑ Put a support under the engine of the motorcycle to ensure that the rear wheel is in air.
- ❑ Unscrew the knurled nut and withdraw the brake pull-rod from the control lever. Dismantle the wheel axle nut and withdraw the wheel using a pin  $\varnothing$  mm.
- ❑ Lean the motorcycle to one side and withdraw the rear wheel by swinging motion.
- ❑ Mounting is carried out in the reverse order.

At mounting take care of correct position of the distance ring and set the rear wheel brake.

## 8.21. Telescopic Fork

The telescopic fork ensures only springing, but not damping. There is a hydraulic stop at maximum springing. The oil fill for one arm is 100 ccm

Oil used: M 3 AD,  
SHELL Tellus C 22,  
CASTROL TQ Dexron

## 8.22. Steering Bearing Clearance Check

Move the telescopic fork arms forward and back. There must be no clearance in the steering bearings. If there is a clearance in the bearings, proceed in following way.

## 8.23. Wheel Bearing Check

If there is a clearance in the front or rear wheel bearings, or if the wheel does not turn smoothly and easily, have the bearings checked in the special service.

## 8.24. Side Stand Check

- ❑ In case of need, lubricate the movable parts with oil of Class SAE 15W-40, and check the stand for smooth travel.

If the side stand drags, contact the special service.

## 8.25. Exhaust Equipment Decarbonization

It is recommended to have the following work made in the special service.

Carbonized end of the exhaust causes decreased power of the engine. Therefore it must be decarbonized.

- ❑ For the exhaust it is necessary to remove carbon from the damping element and exhaust end. Remove the body end with the damping element, and withdraw them from the exhaust body.
- ❑ Clean the surface of the damping element by a scraper. Clean the openings in the damping element and exhaust end by a drill  $\varnothing$  12 mm

## 8.26. Headlight Adjustment

### Headlight Basic Adjustment

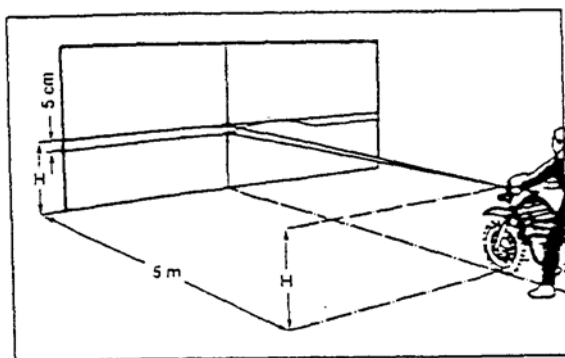
It is recommended to have the following operations made in the special service.

If the setting is changed, it is possible to carry out readjustment in the following way:

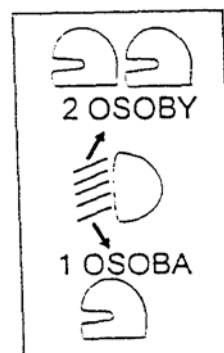
- ❑ Shift the adjusting mechanism in such a way that the boundary between the lower light and upper dark zones will be at least 5 cm below the centre of the headlight in the distance of 5 m.

The motorcycle must have required pressure in its tyres, and must be loaded by one person.

**Figure 38**



**Figure 39**



### Headlight Adjustment Depending on the Motorcycle Load

- ❑ It is possible to correct the headlight position depending on the motorcycle loading by one or two persons.
- ❑ The adjustment is carried out by the corrector lever in the following way (Figure 39):
  - The motorcycle loaded by 1 person - Set the corrector lever to the lower position.
  - The motorcycle loaded by 2 persons - Set the corrector lever to the upper position.

## 8.27. Lamp Replacement

### Front Headlight

Type: **bonneted design**

Check and / or replace the lamps in the following way:

- Dismantle the rear protective cover of the headlight, release the securing spring, and remove the lamp closure.
- Dismantle the lamps of the main headlight and clearance light and check them. Replace them, if need be. Lamp type: Main headlight: 12V 35/35W Clearance light: 12V 5W
- Mounting is carried out in the reverse order.

Type: **Classic**

Check and / or replace the lamps in the following way:

- Release the fastening screw and dismantle the front cover of the headlight.
- Release the securing spring, dismantle the lamp closure, and remove the lamp. Check the lamp and replace it, if need be. Lamp type: Symmetric 12V 35/35 W
- Mounting is carried out in the reverse order.

### Rear Group Lamp

Check and/or replace the lamps in the following way:

- Dismantle 2 fastening screws of the rear group lamp cover, and take out the cover.
- Dismantle the clearance light and stop light lamps. Check the lamps, and replace them, if need be. Lamp type: 12V/ 5W (clearance light) 12V/10W (stop light)
- Mounting is carried out in the reverse order.

### Drive Direction Indicators

Check and/or replace the lamps in the following way:

- Dismantle fastening screw of the direction light cover, and take out the cover.
- Dismantle the lamp, check it, and replace it in case of need. Lamp type: 12V R10W
- Mounting is carried out in the reverse order.

In case that after replacement of a failed lamp by a new one the latter is again damaged, contact the special service immediately.

## 8.28. Fuse Replacement

- The electric installation fuse is accessible after unlocking and lifting the double-seat up.
- Withdraw the ignition and check if the fuse is not blown. If yes, replace it by a new one. Fuse type: knife 7.5 A

### **WARNING!**

Use only the fuses of prescribed value. If you use a fuse with higher amperage, there could be a damage to the electric installation, or a fire.

## 8.29. Battery Check

Good condition of the battery influences correct function of all electric equipment. Therefore take special care of the battery.

The battery is placed in the box under the double-seat, and is accessible after unlocking and lifting the seat up. The battery is delivered charged.

### Electrolyte Level Check

- ❑ Check the electrolyte level monthly. The level should be between the upper and lower lines.
- ❑ In case of need unscrew the closing plugs on the battery and refill the battery with distilled water.
- ❑ Check the deaerating hose for its proper connection and damage and/or fouling.

On long-term storage of the motorcycle remove the battery and store it in a dark and dry place. Recharge the battery before its repeated use.

### Battery Recharging

The battery is recharged by the current of 0.45 A for approx. 10 hours until all cells are gassing with the same intensity and the electrolyte density is 1.23 kg/lit. in all the cells, and voltage on the battery outlets reaches 15 to 16.5 V (measured on the flow of prescribed recharging current).

### WARNING!

Before handling the battery read carefully the following safety rules:

The electrolyte is a caustic, and therefore it requires appropriate care at handling.

Skin stained with the electrolyte must be washed and neutralized by soap or soda. Stained clothes must also be washed in water and neutralized.

It is forbidden to use open fire close to the battery.

## 8.31. Table of Failures

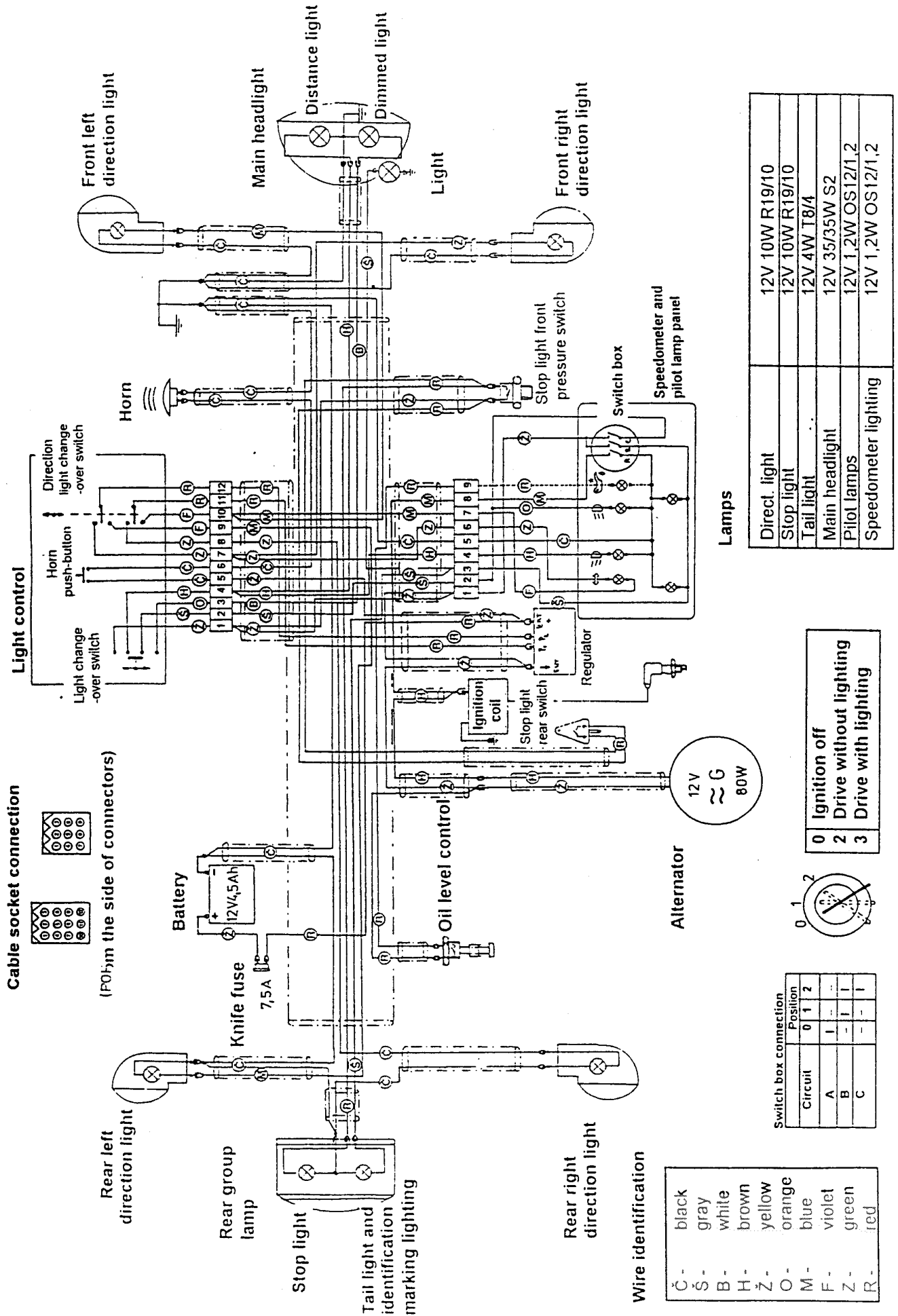
### WARNING!

It is forbidden to smoke or use open fire close to the motorcycle on fuel system inspection.

	<b>Failure</b>	<b>Failure Cause</b>	<b>I</b>	<b>Failure Removal</b>
Ignition	Sparking plug without sparks, or with low sparks	- Wet sparking plug - Faulty sparking plug - Ignition failure - Cable socket incorrectly put on		Dry and clean it Replace it Special service Put it on properly or replace it
Fuel System	Engine misfires at acceleration Engine does not work on idle-run No fuel in the carburetter	- Wrong fuel used - Dirty in carburetter - Carburetter failure - Carburetter set incorrectly - Empty fuel tank - Clogged fuel screen in carb. or tank		Use prescribed fuel Clean the carburetter Special service Special service Refill it with prescribed fuel Clean and/or replace it
Engine	Insufficient power	- Carburetter failure - Cylinder head leak - Worn out or damaged piston rings - Carbonized exhaust system - Clogged air filter of the carburetter - Untightness of exhaust/intake piping		Special service Special service Special service Clean it Clean or replace it Tighten the joints. Replace the defected parts by new ones.
Braking System	Ineffective front brake	- Braking system untightness  - Brake plates worn out - Air in the circuit - Wrong setting of the pedal clearance - Worn out lining of the rear shoes		Replace the defective parts by new ones Replace them by new ones Deaerate the circuit Adjust it Replace it by a new one

### 8.30. Electric Installation Diagram

Electrical equipment location and wire identification



## 9. Care of the Motorcycle

- ❑ Regular and special care helps to maintain the motorcycle in appropriate technical state, and guarantees its safe use, without expensive repairs that should have occurred if you neglect the regular maintenance.
- ❑ The regular prescribed care of the motorcycle is also the presupposition of guarantee claims in case of failures, if any.

### 9.1. Cleaning

Regular washing not only improve look of the motorcycle, but also increases its service life.

#### **WARNING!**

Use of an excessive pressure of water and aggressive cleaning agents or high-pressure cleaning machines (steam ones with high temperatures) can cause damage to varnish, release of decorations, and damage to the wheel bearings, brake drums, front fork, engine, and carburettor intake system!

- ❑ Before cleaning seal the exhaust piping end to prevent water from getting in. Use eg. plastic bag secured by a rubber band.
- ❑ Check if the sparking plug is screwed in and all filling plugs are tightened.
- ❑ For very dirty engine it is recommended to use cleaning agents for engines such as SONAX Motor and Kalt Reiniger. Wash out the cleaning agent and grease with a flow of water. Do not use higher pressure of water than it is necessary.
- ❑ After washing main dirt off the motorcycle, wash its surface by tepid water with a car shampoo. After it, wash the motorcycle immediately with clean water and dry it by buck leather or good absorbing cloth.
- ❑ Dry the chain and grease it using a spray for chains eg. CASTROL Super ketten spray, TEXACO Ketten spray.
- ❑ Clean the seat by a cleaning agent for upholstery surfaces eg. RIVAX Cockpit spray to remain soft and glossy.
- ❑ Apply a mean for rubber protection such as RIWAX Gummi-Reiniger to rubber parts and tyres.
- ❑ It is possible to use a car wax to all varnished and chrome-plated parts.
- ❑ After cleaning start the engine and let it idle run for a short time.

### 9.2. Motorcycle Storage

Long-term storage of the motorcycle requires to use preventive actions to prevent from deterioration of its technical state. First of all, the motorcycle must be washed and prepared in the following way:

- ❑ Discharge the fuel tank and carburettor float chamber.
- ❑ Dismantle the sparking plug and pour 2 to 3 ccm (tea spoon) of engine oil into the hole. Mount the plug back, and then turn the engine several times using the starting lever (with the ignition off) to cover the cylinder walls with oil).
- ❑ If you do not intend to use the motorcycle a month or more, dismantle the battery and store it in a dark and dry place. At long-term storage measure the electrolyte density once a month, and if it is low, recharge the battery.
- ❑ Dismantle the driving chain, clean it with kerosene perfectly, and grease it. Then mount it back or store it in a plastic bag.
- ❑ Lubricate all Bowden cables with oil of Class SAE 80 (See Section 8.3.)
- ❑ Put a plastic bag onto the exhaust piping end and secure it by a rubber band to prevent moisture from getting in.
- ❑ At storing in wet or sunny environment, apply thin film of oil to all metallic parts of the motorcycle. Do not apply the oil to rubber parts or seat.

Before storage check the motorcycle properly and remove all defects found.

### 9.3. Winter Operation and Protection against Corrosion

- ❑ If the motorcycle is used in winter months, spreading salts can cause sufficient damage to the undercarriage and engine, if you do not realize important counter measures and/or preventive actions.

## Recommendations

After a longer drive it is recommended to clean the aluminium parts of the motorcycle by a cleaning agent or to brush them, wash with water, dry them and apply an anticorrosive protection by a preservative agent.

### 9.4. Fuel Saving

- ❑ Have the damaged brakes repaired immediately.
- ❑ Accelerate smoothly at start.
- ❑ Do not overload the engine by higher speed than stated by the manufacturer.
- ❑ Check air pressure in the tyres.
- ❑ Check wheel bearing clearances.
- ❑ Carry out maintenance and adjustment of the driving chain.
- ❑ Replace the sparking plug according to the data prescribed by the manufacturer.
- ❑ Have the ignition system checked regularly in a special service.
- ❑ Have the carburettor function checked regularly in a special service.
- ❑ Replace the air filter according to the data prescribed by the manufacturer.
- ❑ Have overall inspection and/or adjustment of the motorcycle carried out in a special service regularly.
- ❑ Have the exhaust piping end cleaned in time.
- ❑ Do not do any design changes on the carburettor and/or exhaust system.

### 9.5. Ecologic Information

Engine oil, gear oil and fuel contain the matters harmful to the environment. Observe relevant ecologic rules for their handling and liquidation. Always give the spent oil to the organization that ensures their liquidation or other utilization.

Your motorcycle includes materials that can be recycled. After the end of their service lives specialized companies will take care of their sorting and recycling. Please be informed of local possibilities of removal these materials.

### Notice

---

We reserve the right of changes compared with the textual and illustrative part of this manual due to the product development.

#### Issued by:

Commercial and Technical Services  
**MOTOR JIKOV, a.s.**  
Kněžskodvorská 26, 370 04 České Budějovice  
January 1996

---